

# **Softbank NSO Use Case and SDN NFV Initiative**

**June 18<sup>th</sup> 2019**

**Director, Solution Service 1<sup>st</sup> Dept.  
Hironori Nakano**

**SDN Architect, IaaS Engineering Dept.  
Kentaro Someya**



**Speaker : Nakano**

- 1. Introduction of SoftBank & Data NW business P03-12**
- 2. SoftBank SDN business overview P13-19**

**Speaker : Someya**

- 3. SDN/NFV tech details P20-33**



# Introduction of SoftBank & Data NW business



## “Information Revolution” for the world



Founded

**September 3, 1981**

Chairman & CEO

**Masayoshi Son**

Common Stock

**JPY 238,772 million**  
(As of March, 2018)

Consolidated Sales

**JPY 9.6022 trillion**  
(FY 2018)

Number of Employees  
(consolidated basis)

**74,952**  
(As of March, 2018)



**SoftBank Group**  
**Strategic Holding Company**

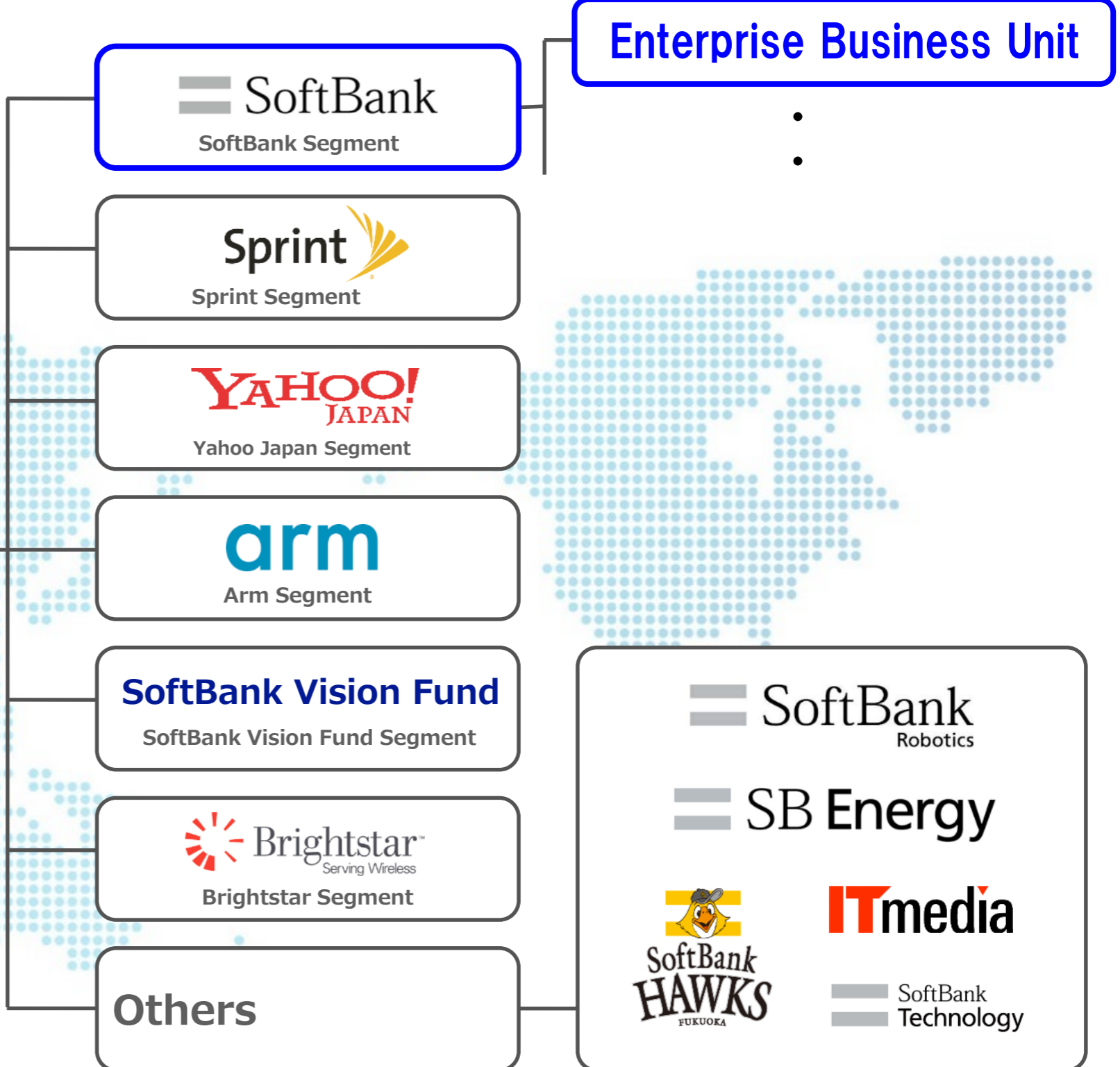

**Our strategic synergy group is expanding globally**



## EBU Mission

# Innovate customers' businesses and society

With cutting-edge technologies





## Communications businesses to cutting-edge technologies

### Mobile/Fixed-line phone

SoftBank

Y!mobile

おとくライン

Optical IP telephony

### Network/Cloud/Security

SmartVPN

ASPIRE

G Suite

Office 365

Google Cloud Platform

Alibaba Cloud

ZIMPERIUM.

cybereason

### Digital marketing

GENERATE

cinarra

arm TREASURE DATA

ウルトラ集客

### AI/RPA

IBM Watson™

FINDABILITY SCIENCES

MAGELLAN BLOCKS

SynchRoid

### Robot

pepper for Biz

AI清掃PRO  
brainOS powered

BostonDynamics

### IoT

SoftBank IoT Platform

Sumakagi

nauto

ENERTALK

handy.



We started the provision of working spaces.  
**wework**

SB is enhancing SmartVPN value with developing **various value added services.**

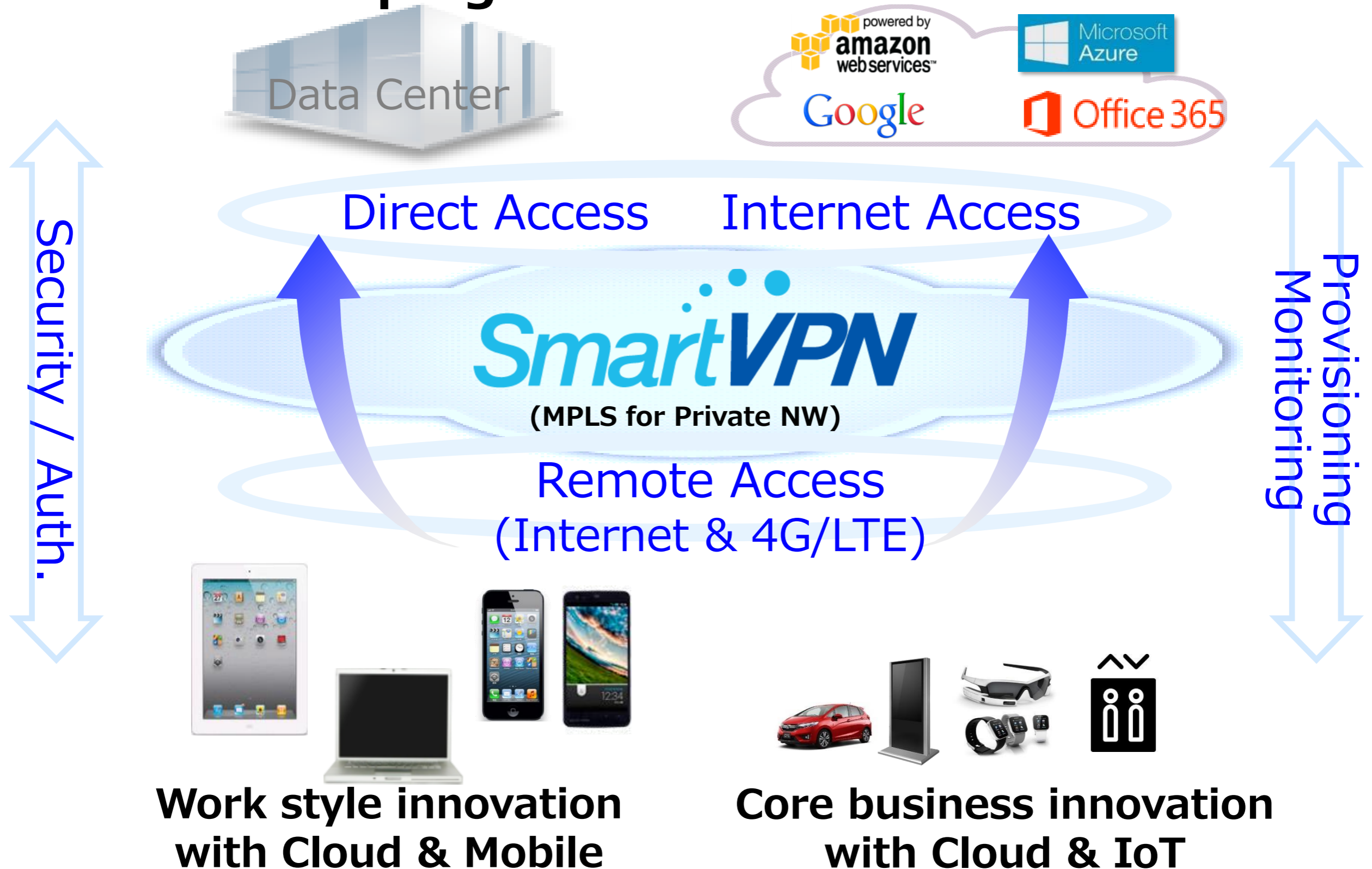



## GW services between SmartVPN and Internet/Mobile

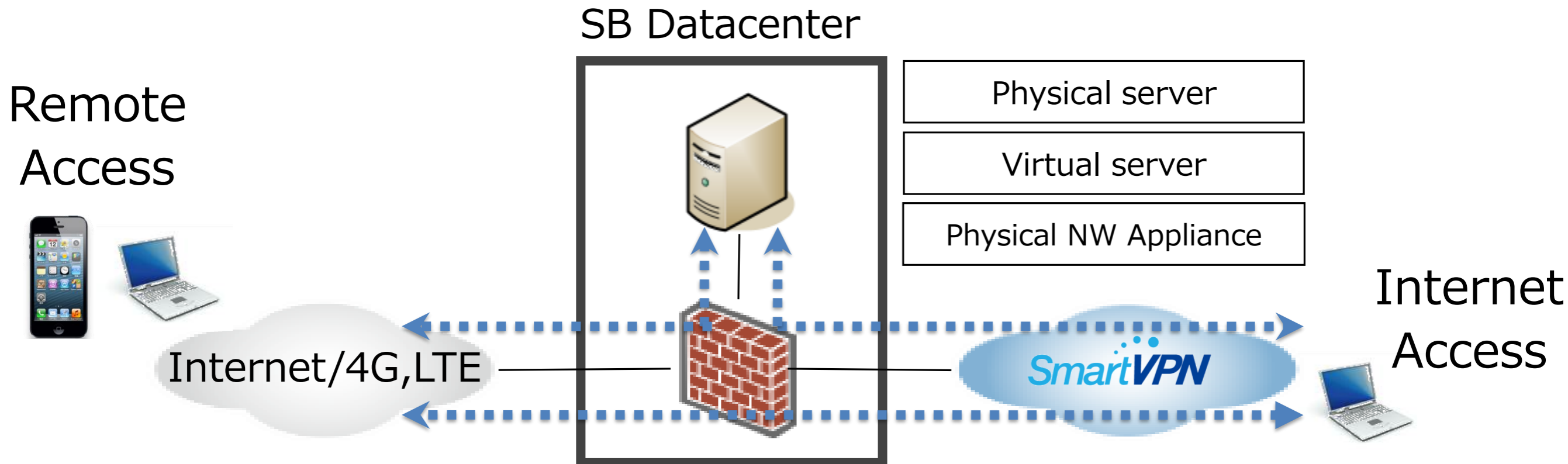

Network	Web Security	Mail Security	Server
<ul style="list-style-type: none"> <li>• SSL VPN</li> <li>• UTM</li> <li>• Load balancer</li> <li>• P-GW</li> </ul>	<ul style="list-style-type: none"> <li>• Web Filtering</li> <li>• HTTP Virus Check</li> <li>• Proxy</li> </ul>	<ul style="list-style-type: none"> <li>• Virus Check</li> <li>• Spam Prevention</li> <li>• Mail Archive</li> </ul>	<ul style="list-style-type: none"> <li>• Mail/Web</li> <li>• Airwatch GW</li> <li>• RADIUS</li> </ul>

Managed Security Service(Security monitor and Security management)

**We are offering reasonable multi-tenant service and highly functional dedicated service.**

These items influenced to our competitiveness.

## 1. Long delivery time

- Delivery time for new contract = 1 month ~
- Configuration change(ex. FW policy) = a few days ~

## 2. Operator's workload continue to increase...

- Workload increases in proportion to customers.
- Deploy "by hand" is not efficient...

## 3. Capex/Opex continue to increase...

- Old, high cost appliances still remain.

We tried to introduce new SDN infrastructure that could deploy and configure services automatically.



Not only GW but also SmartVPN PE, Direct Access

Category	Function
Cloud Access	Direct Access
WhiteCloud Gateway	F/W
	Web Filtering
	Secure Proxy
	HTTP Virus check
	Mail Security
	Load Balancer
	Radius
	Remote Access
	DHCP Relay/Server
	Access List
PE	

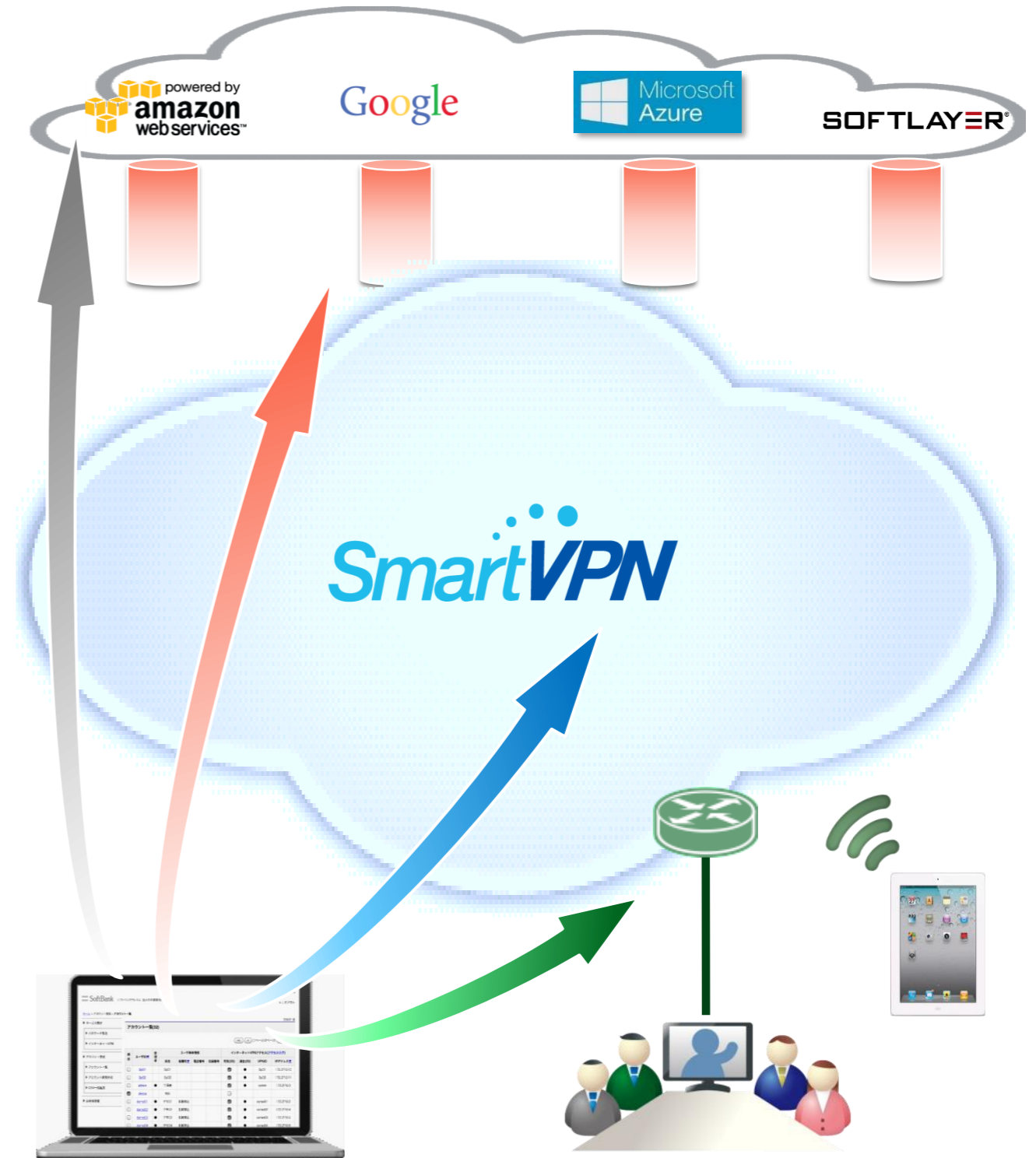

SB will launch in Feb 2016!!

NSO creates north-band API automatically for SB service model.

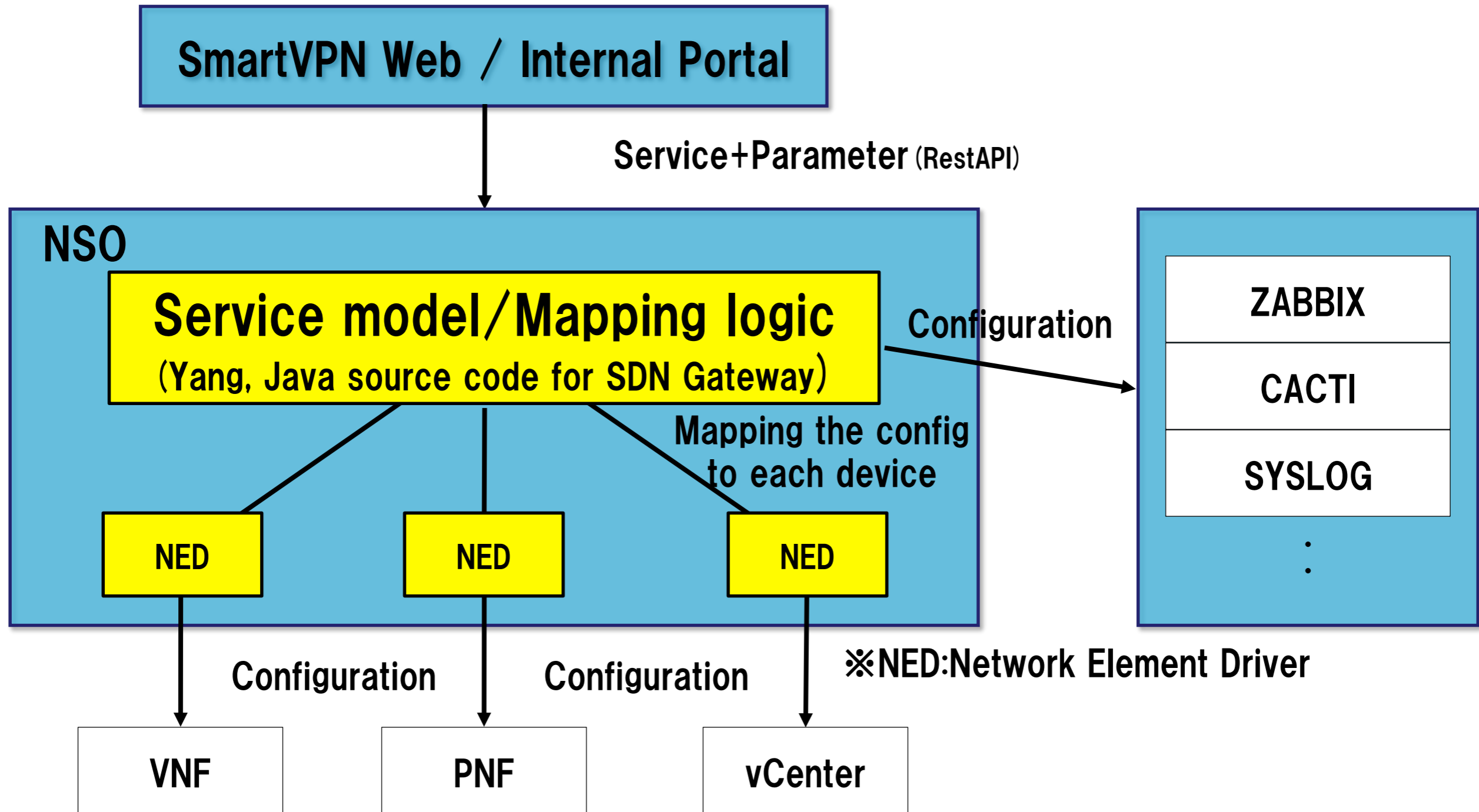

Operator can deploy PNF/VNF, setting through portal quickly.





# SDN/NFV Business Overview

After launch at Feb 2016, we proceeded two project in parallel.

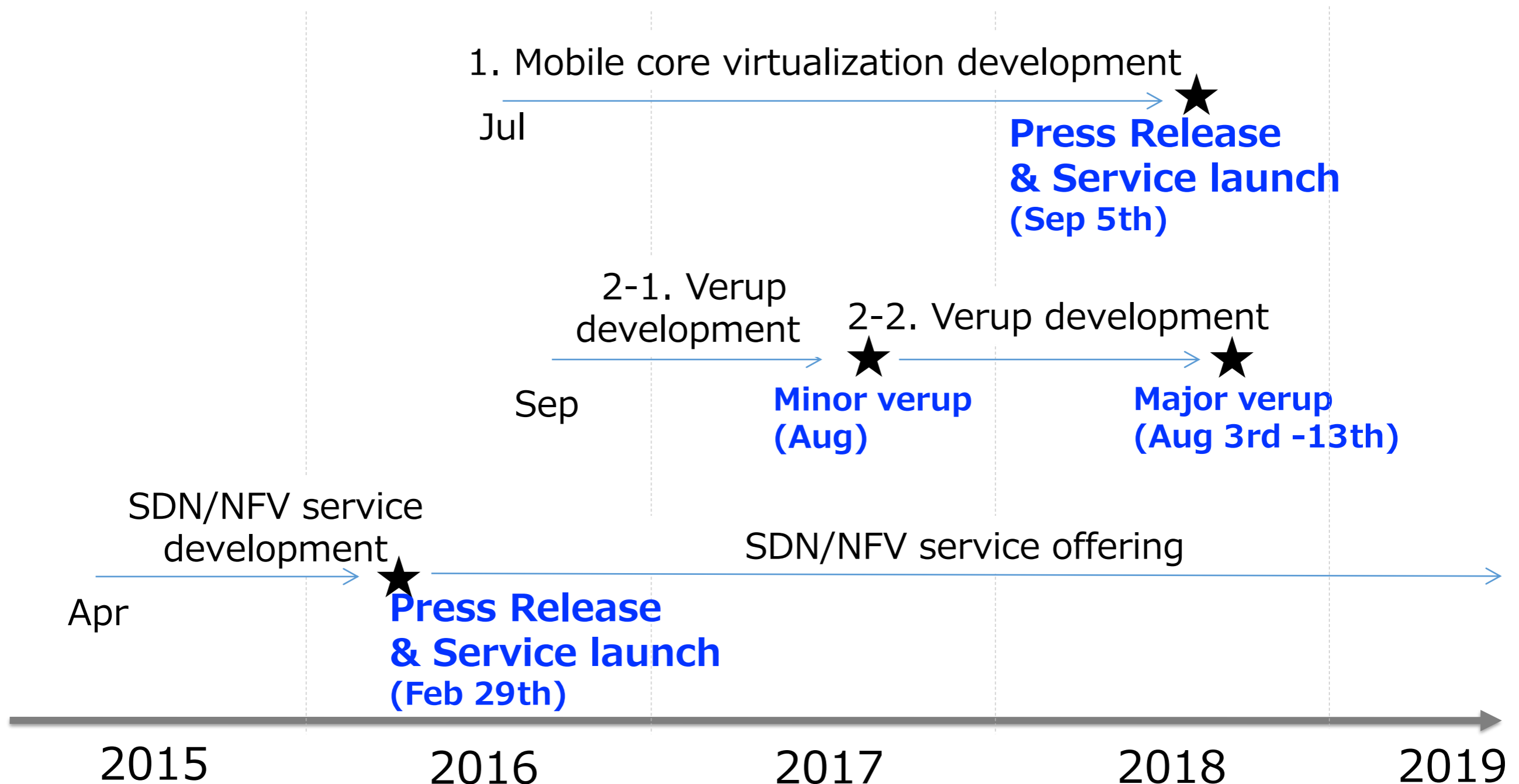



**SB has launched virtualized P-GW service for IoT deals with Affirmed networks product at Sep 5<sup>th</sup>.**

## Before(Old service)

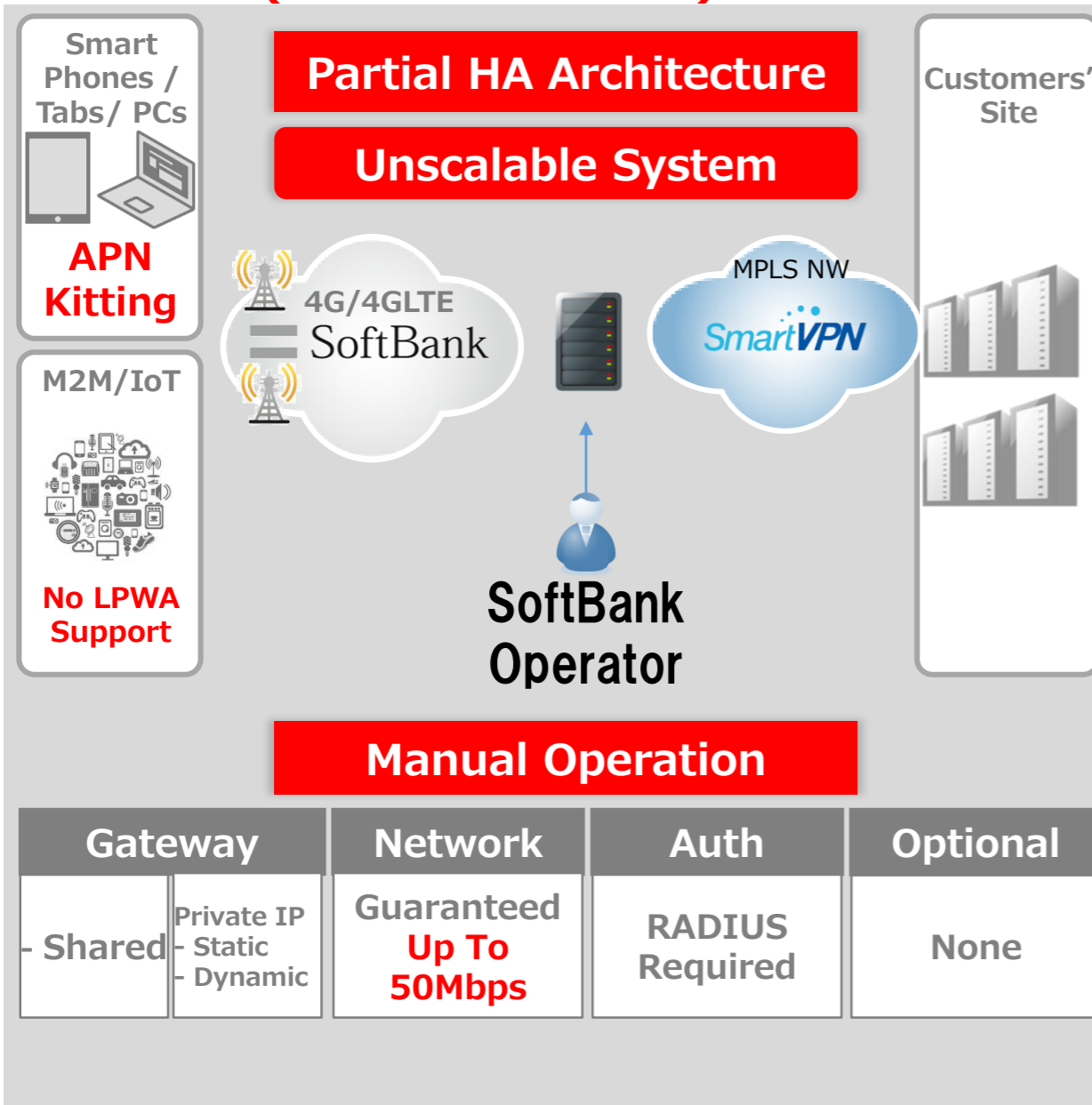

## After(New service)

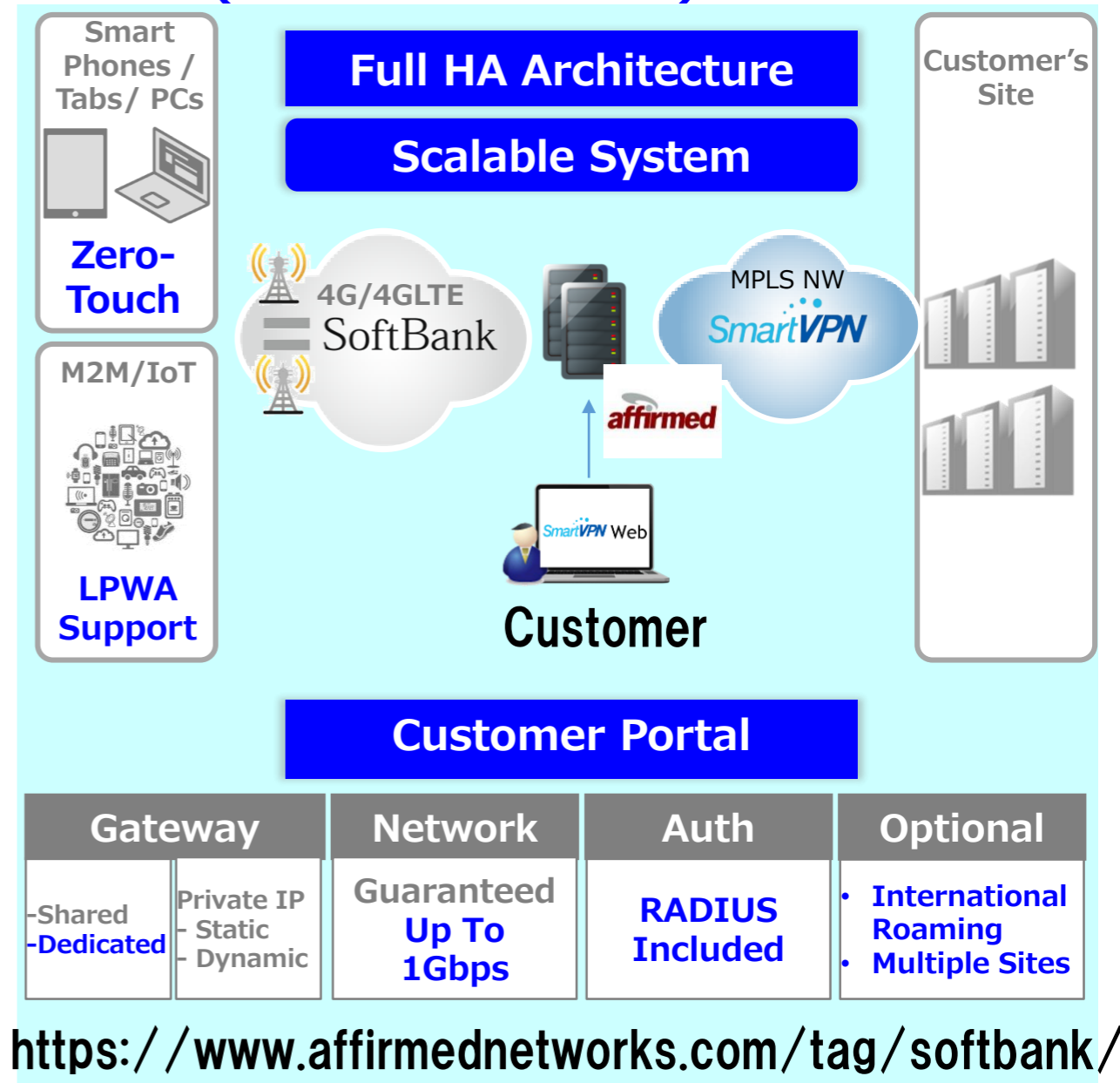

**NSO is used for configuration of router between MPLS PE and P-GW.**

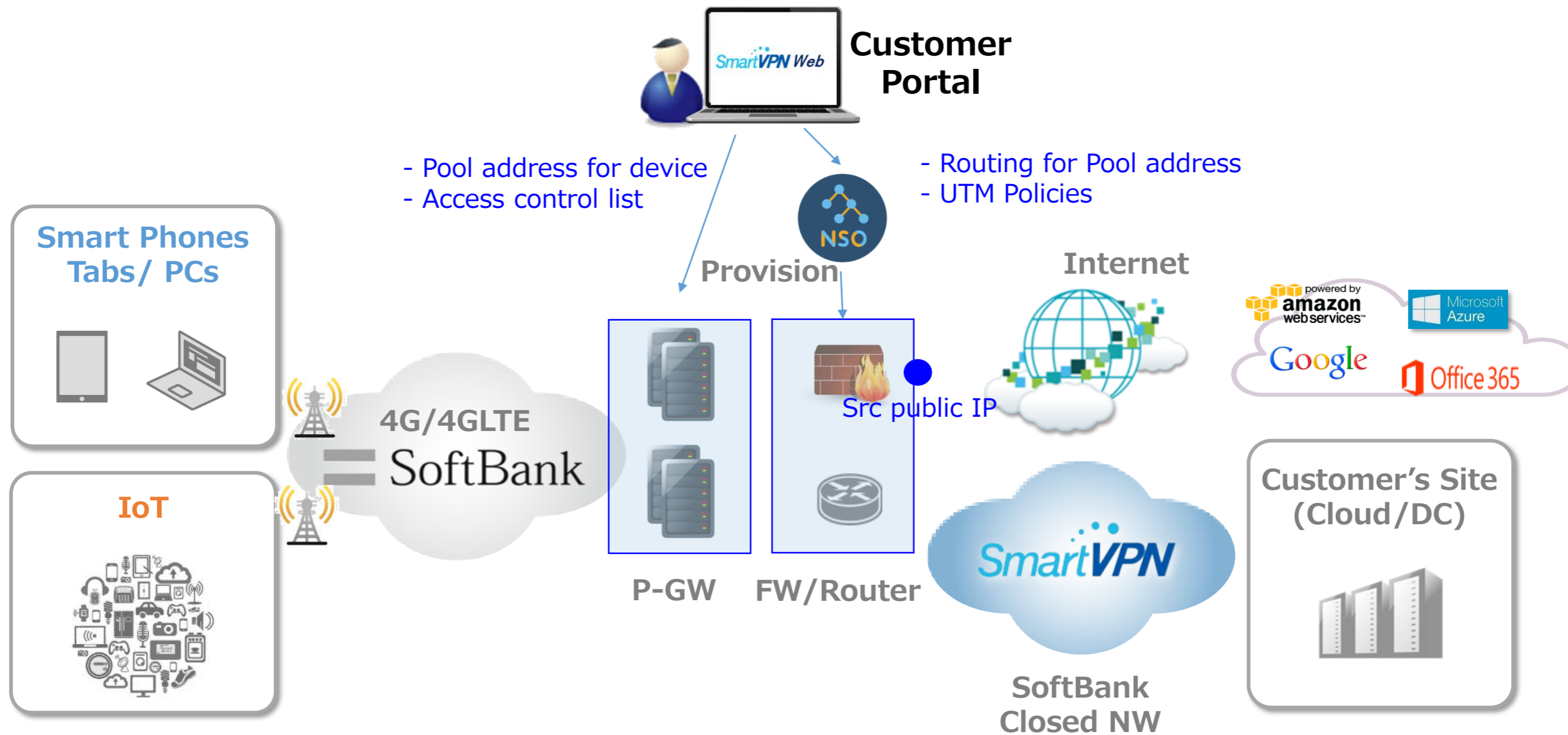

- **Connected car(2M+ sub)**
- **Smart meter for electricity charge(0.8M+ sub)**
- **PC/Smart devices Internet access with fixed src public IP on FW**

**SB migrated from NCS to NSO with 1-year development.**

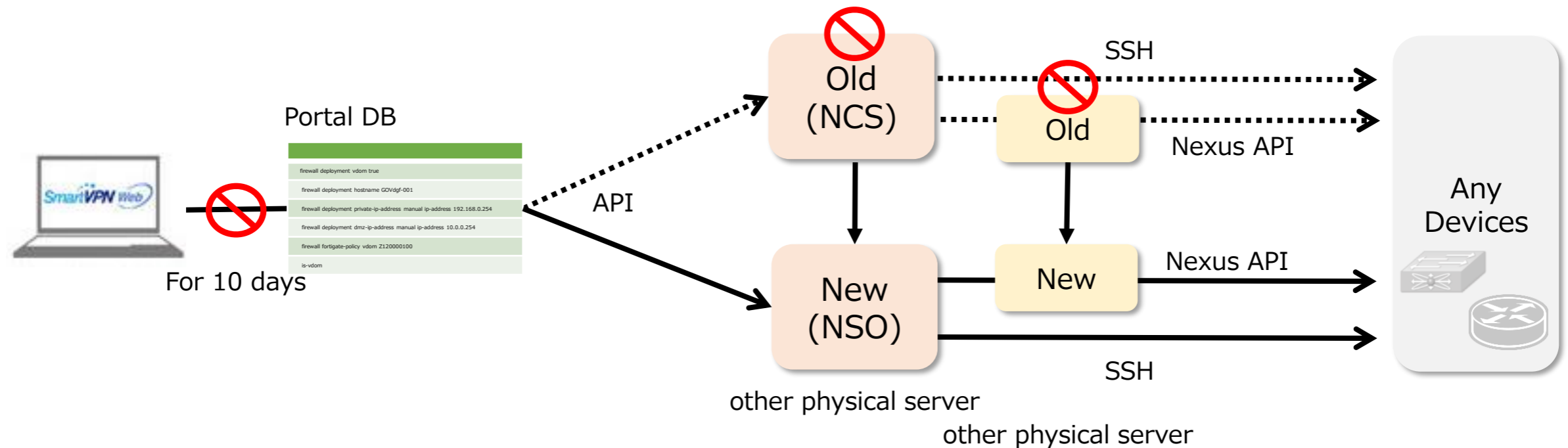

**Long term development was big challenges.  
We needed to shorten this term.  
(Someya will explain our solution later.)**



**After launch, SDN based services extend share eventually.**

SDN based services ratio on the number of total GW customer

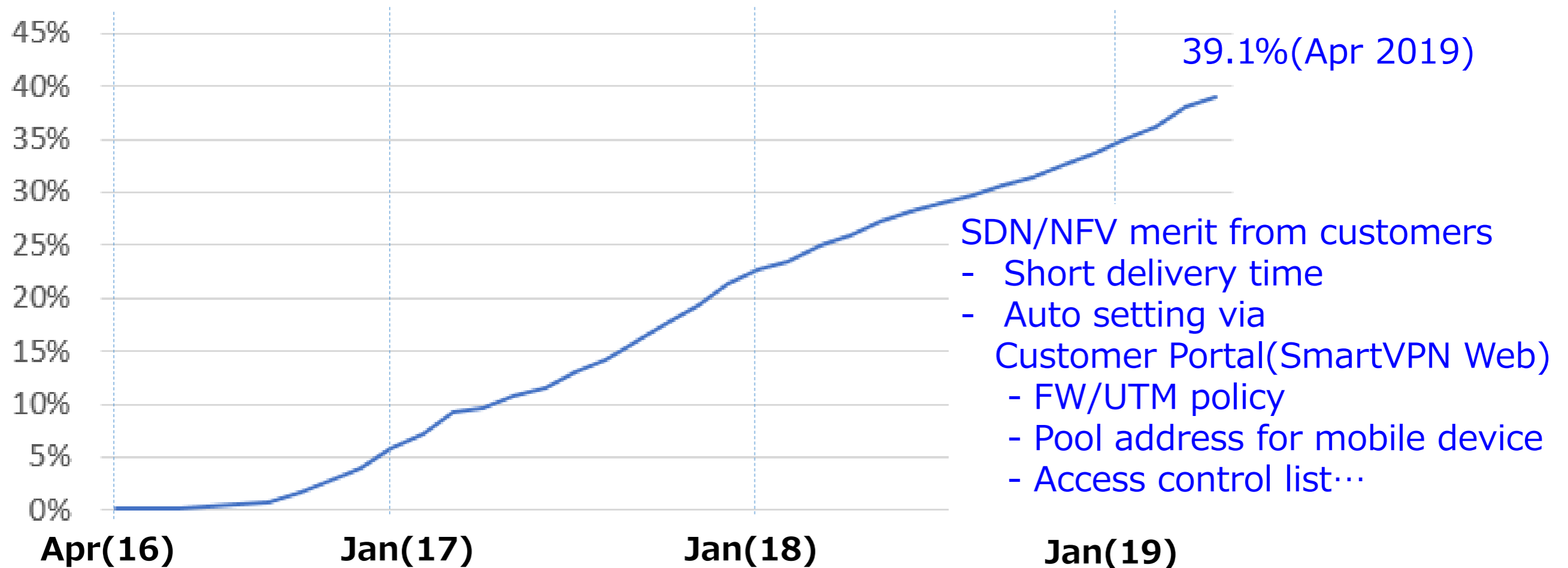

**We aim to exceed 60% by the end of FY20.**

## Security Automation, Cloud connection, Wide bandwidth

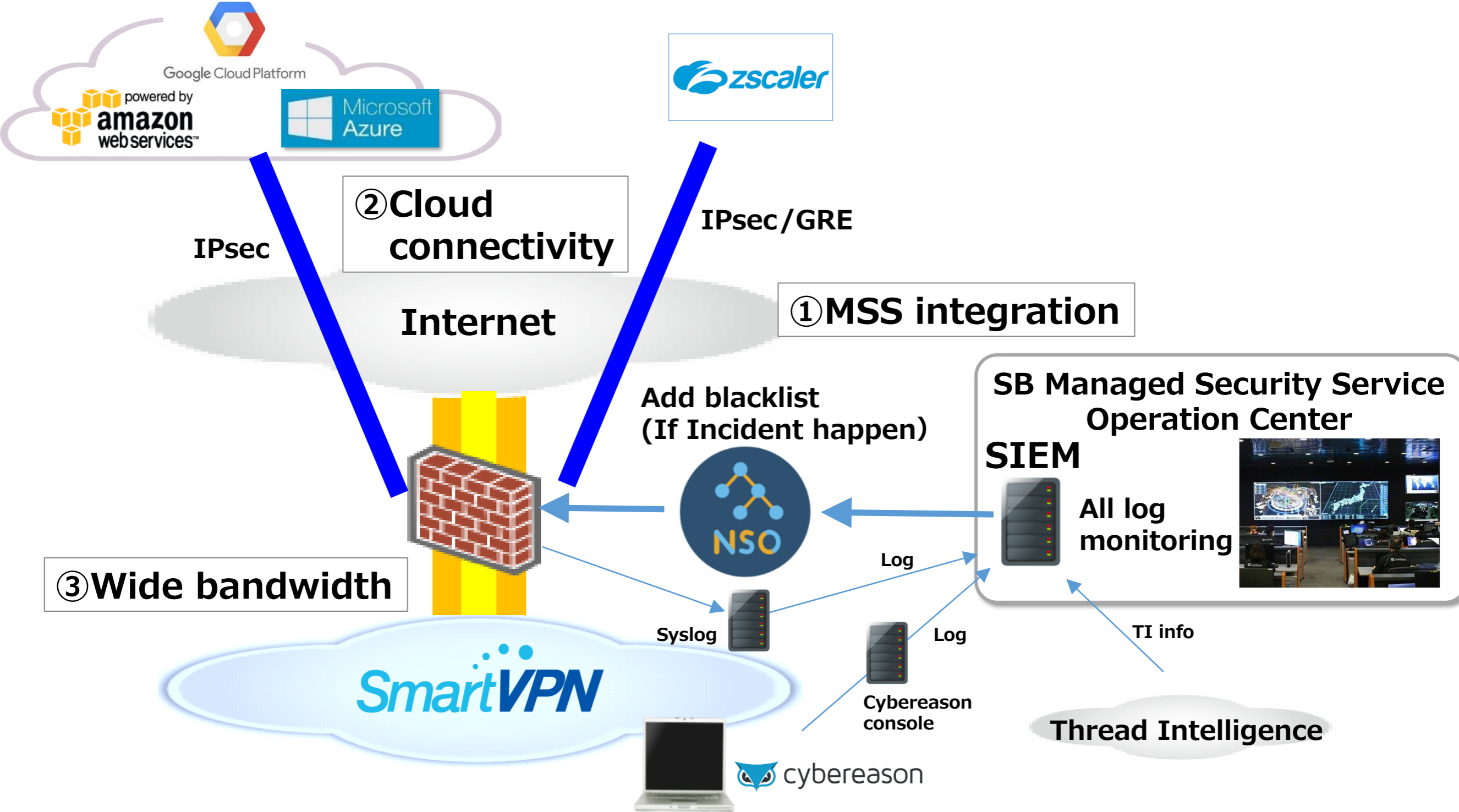



# SDN/NFV tech details



# Before using Orchestrator

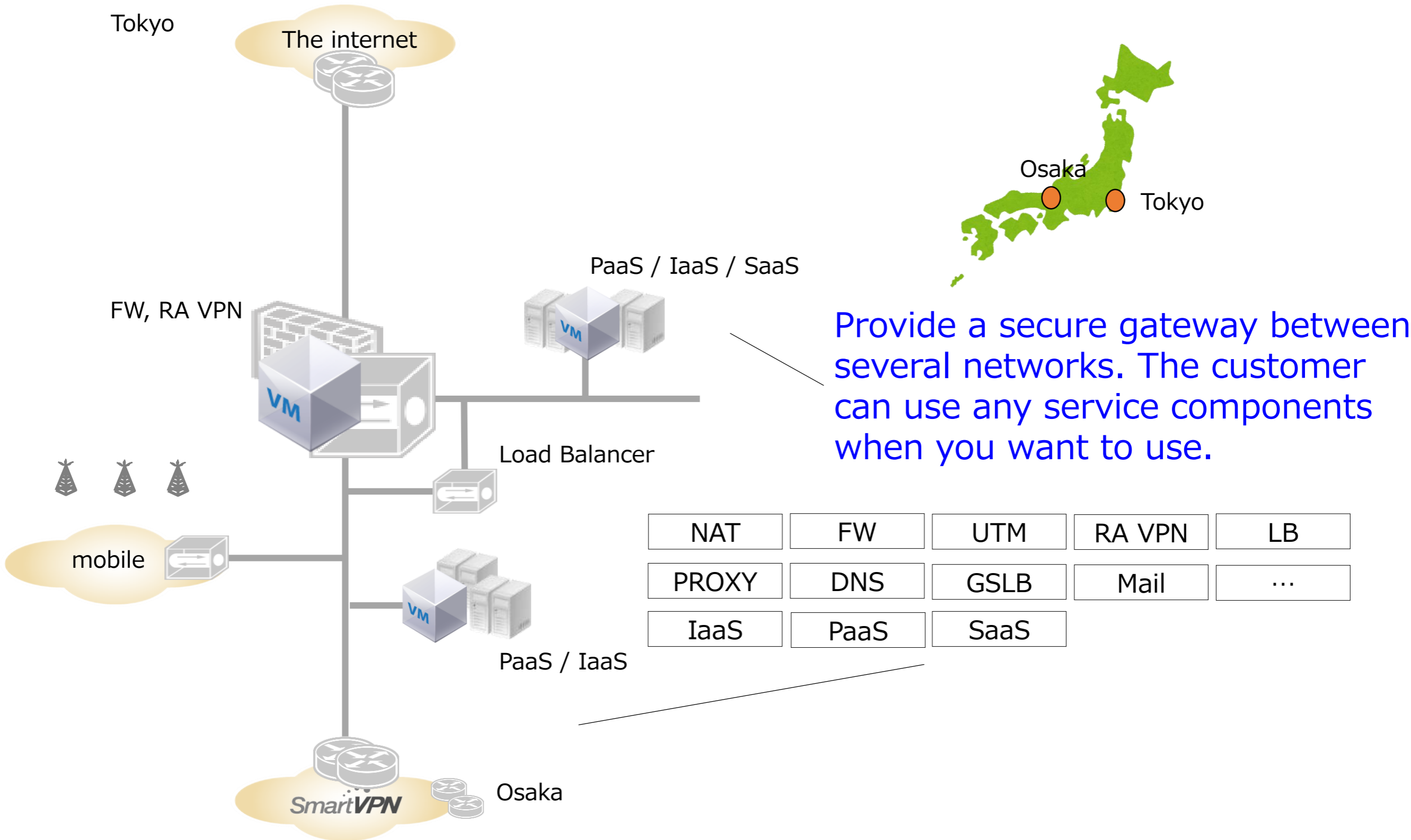

# Before using Orchestrator

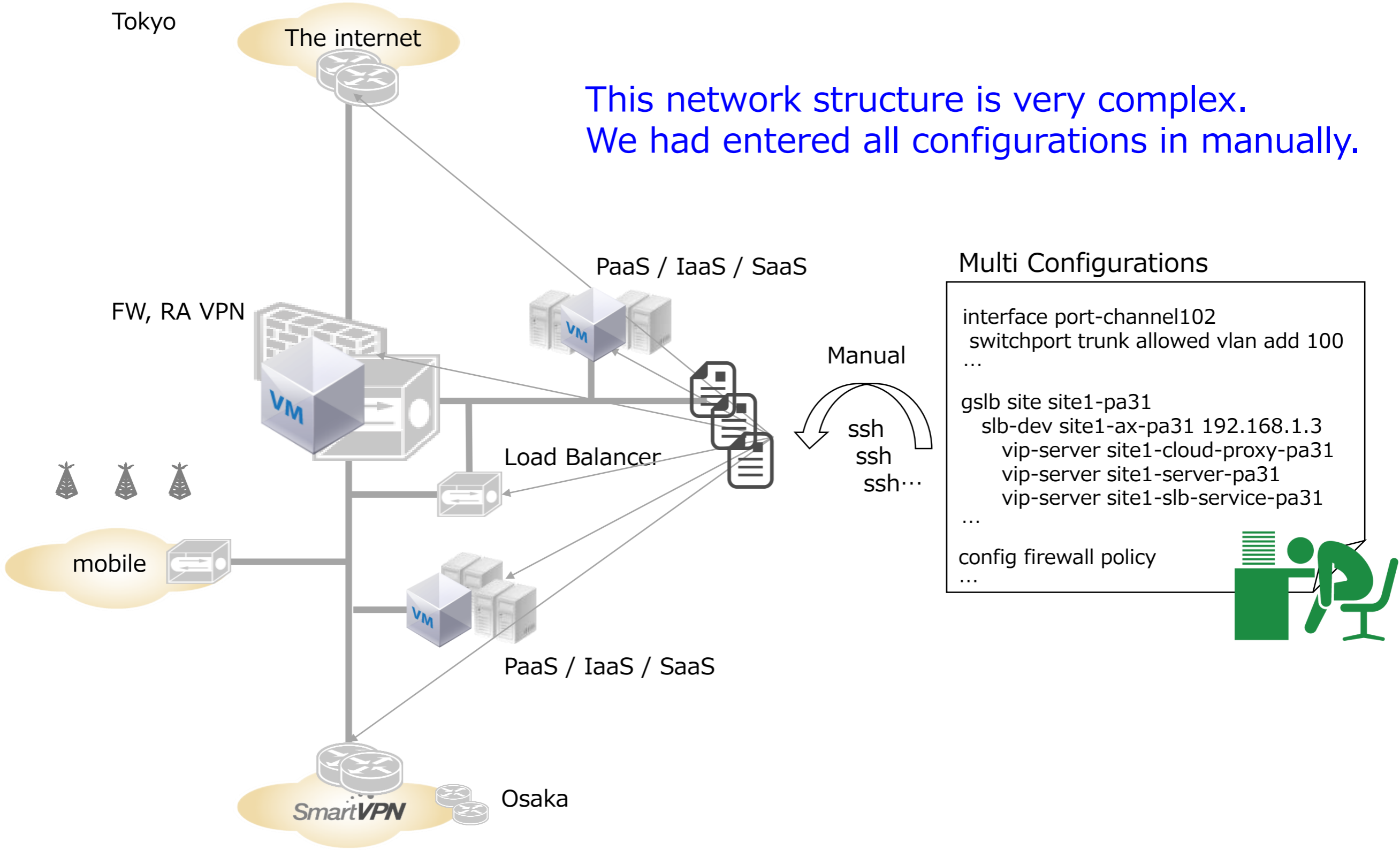

This network structure is very complex.  
We had entered all configurations in manually.

Multi Configurations

```
interface port-channel102
switchport trunk allowed vlan add 100
...
gslb site site1-pa31
slb-dev site1-ax-pa31 192.168.1.3
vip-server site1-cloud-proxy-pa31
vip-server site1-server-pa31
vip-server site1-slb-service-pa31
...
config firewall policy
...
```

# After using Orchestrator

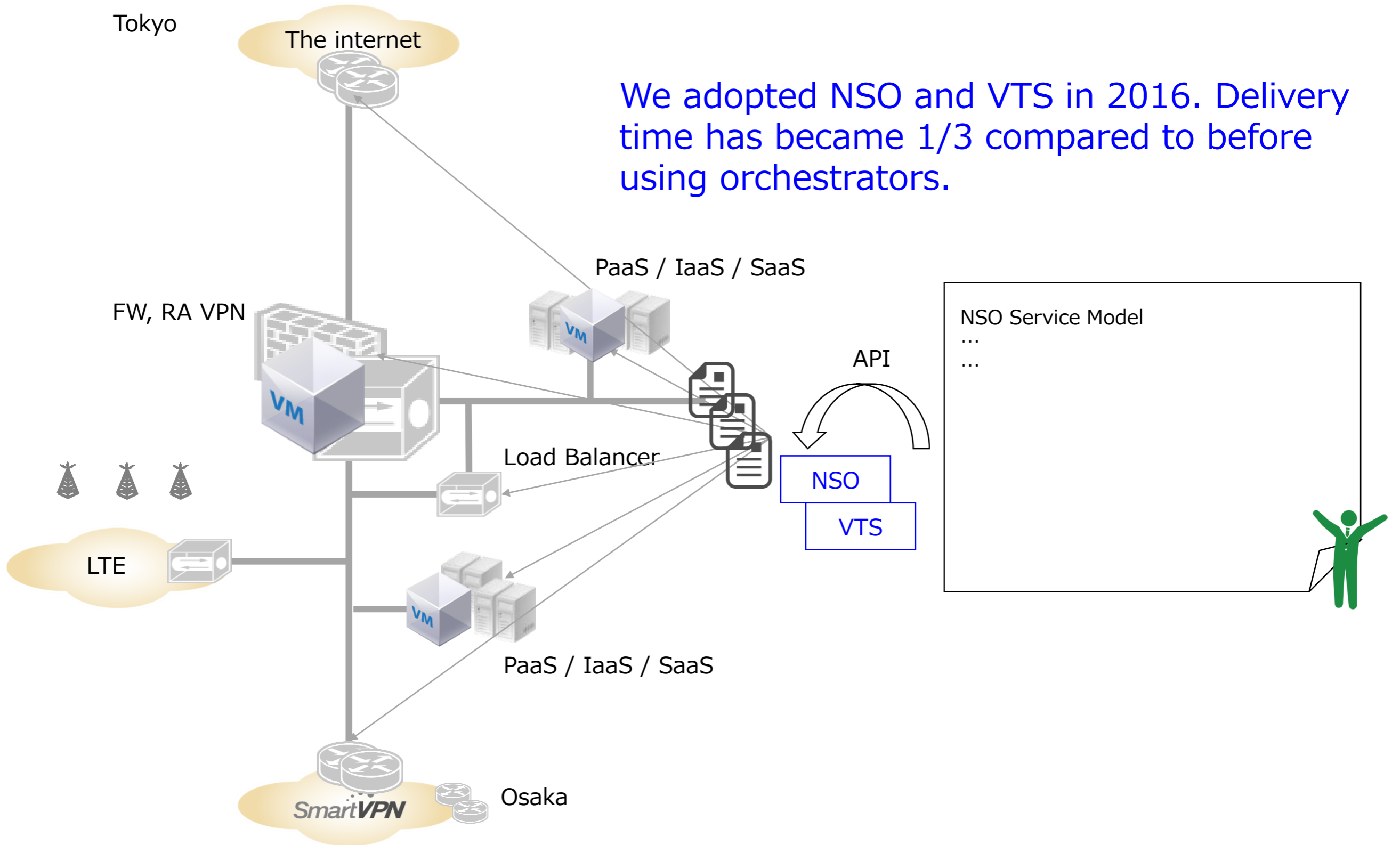



# Our Gateway Architecture

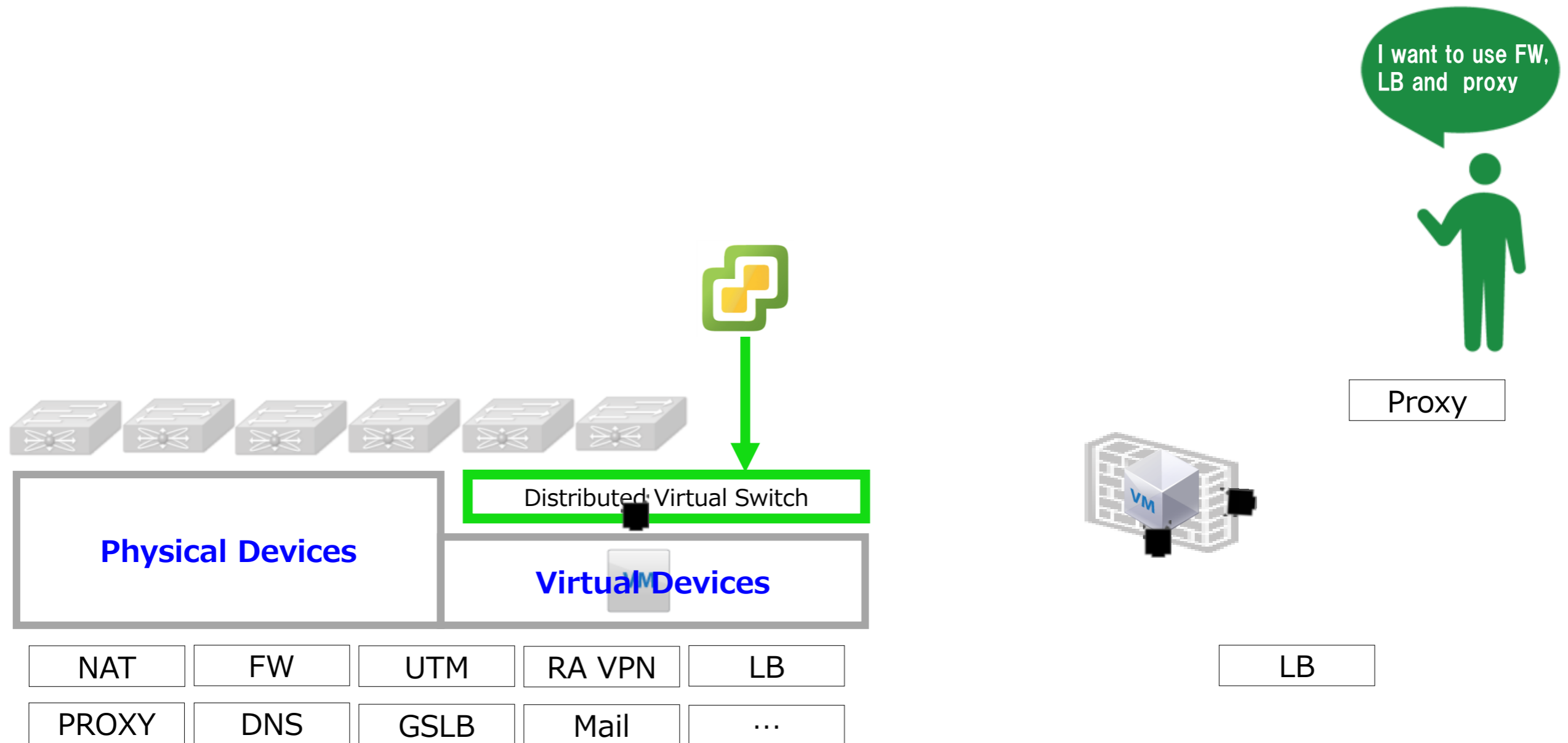

These devices are easily connected via vxlan and vlan using the SDN controller (Cisco VTS).

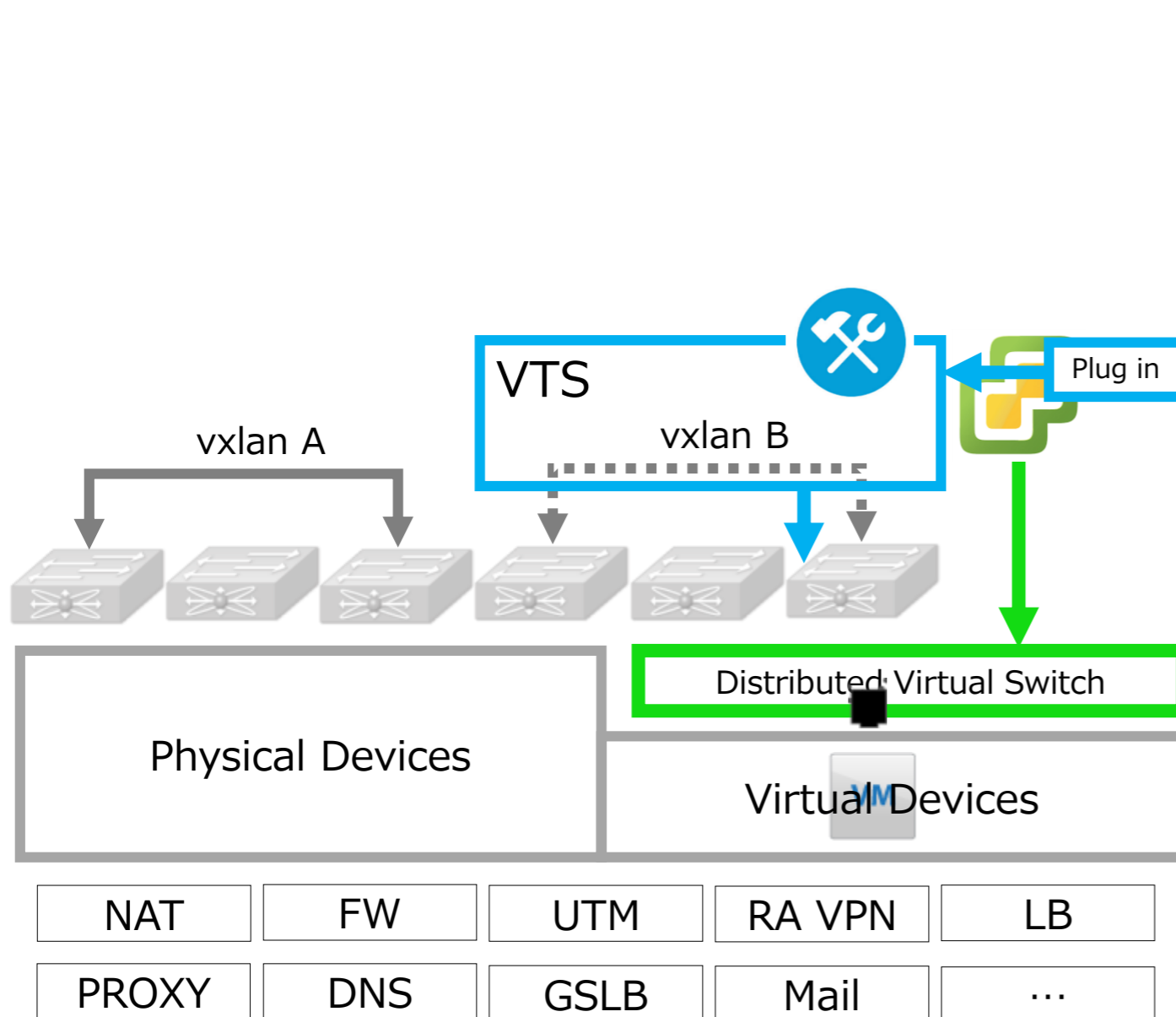

Portgroups with the specific vlan are created automatically.

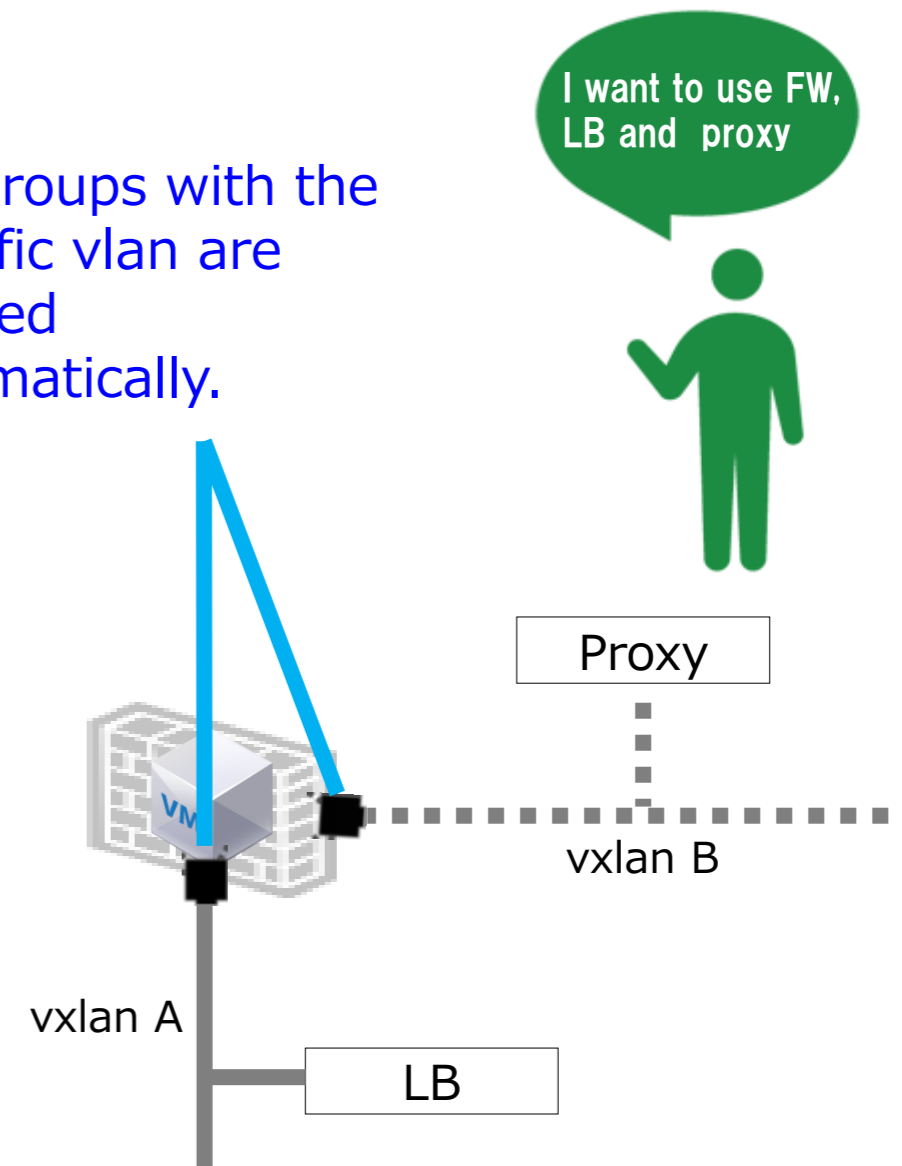

# Our Gateway Architecture

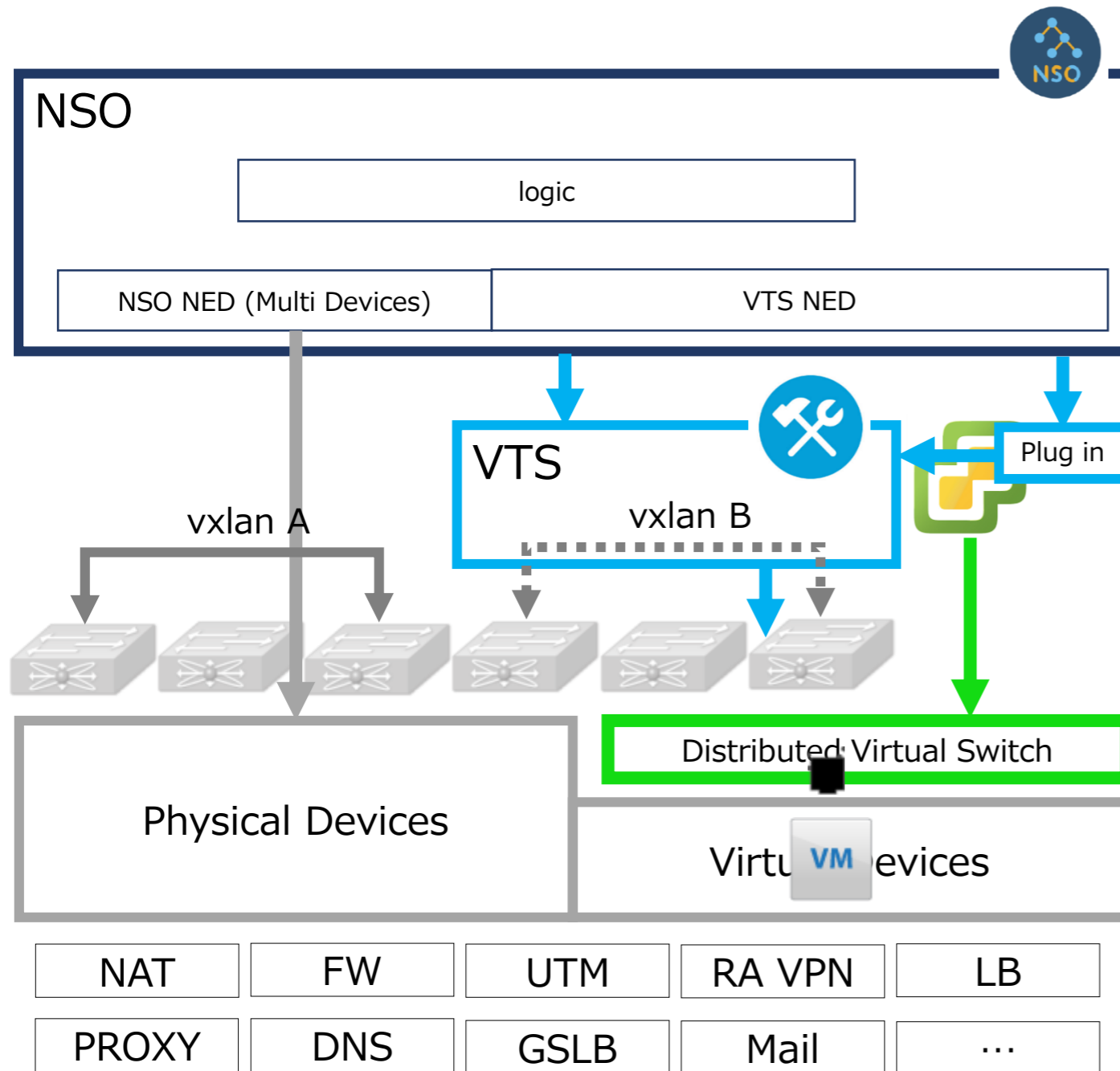

The many configurations are done by Cisco NSO.

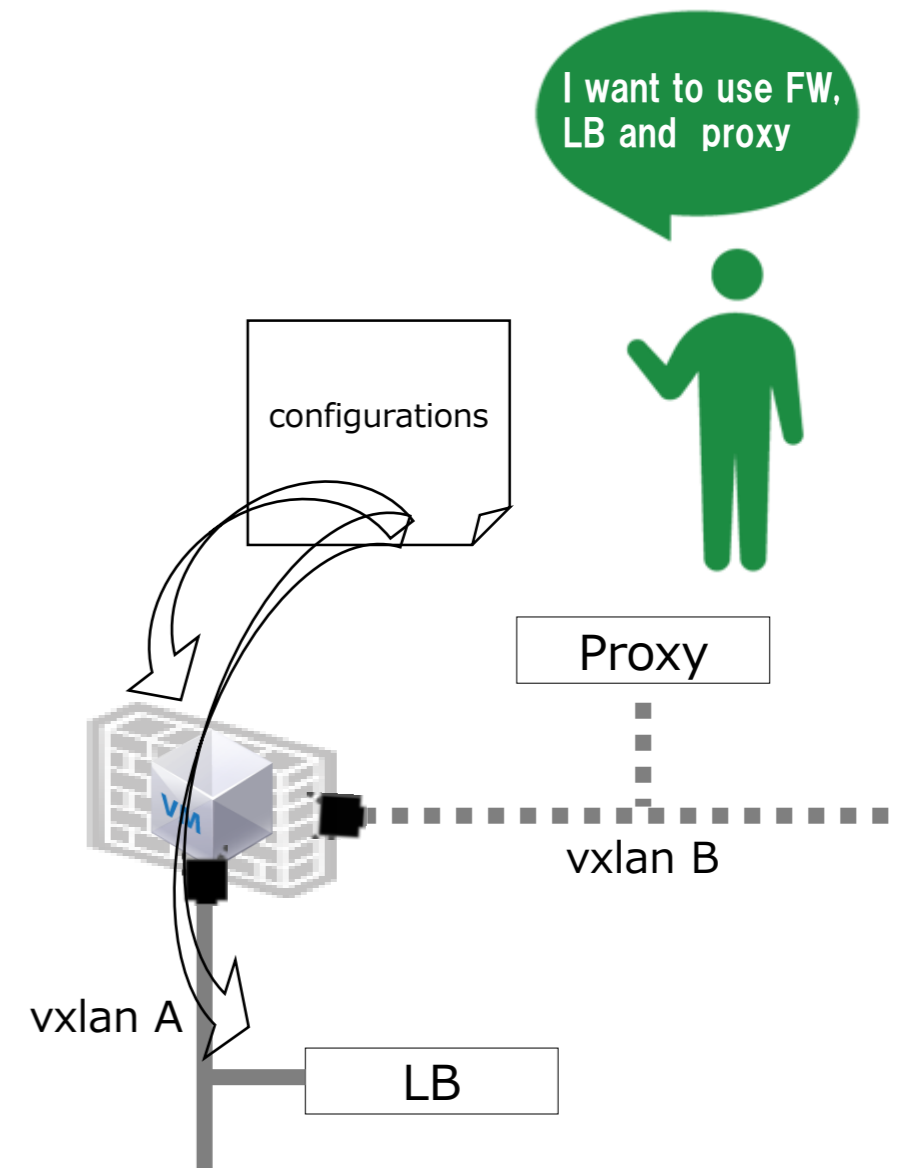

# Our Gateway Architecture

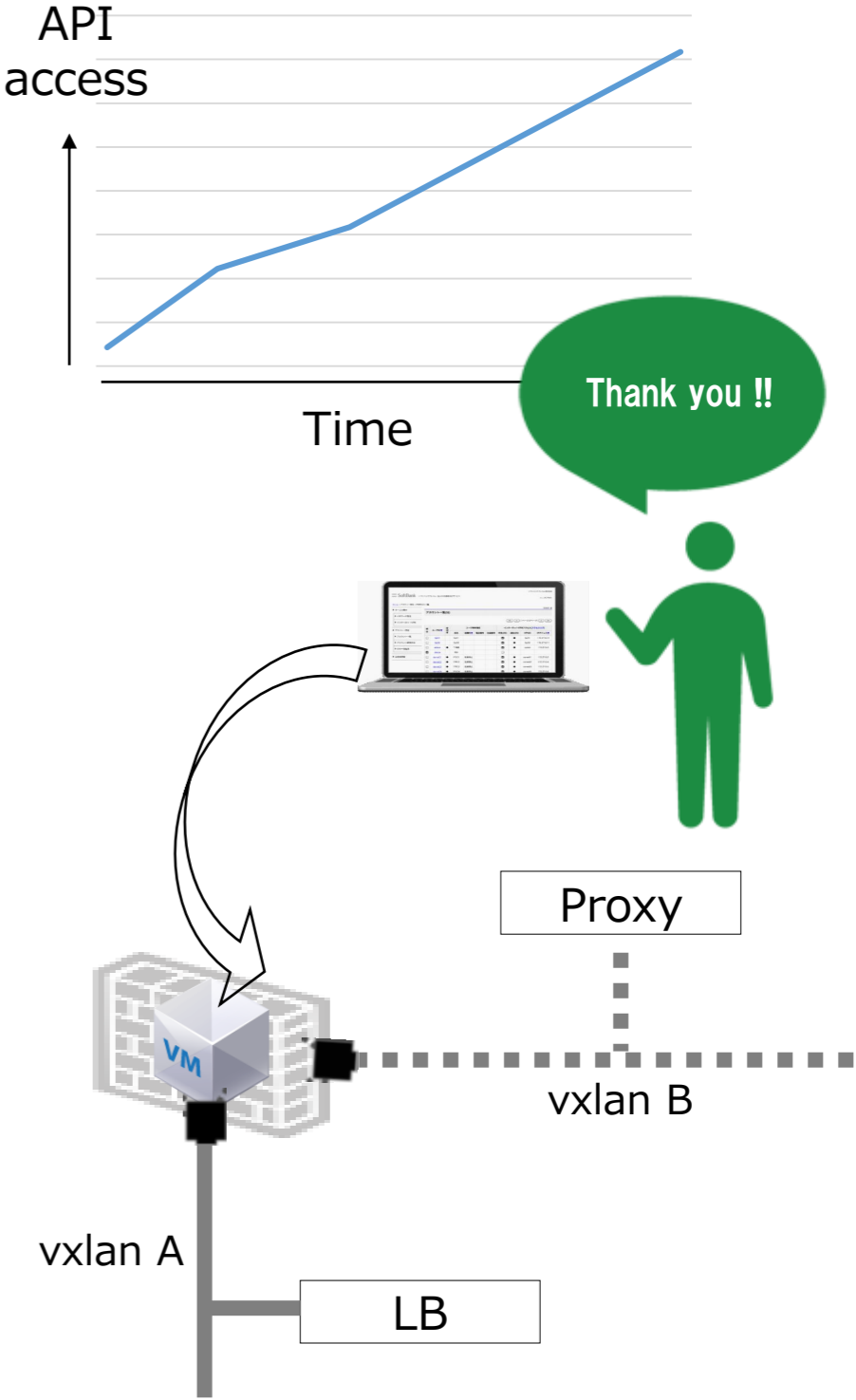
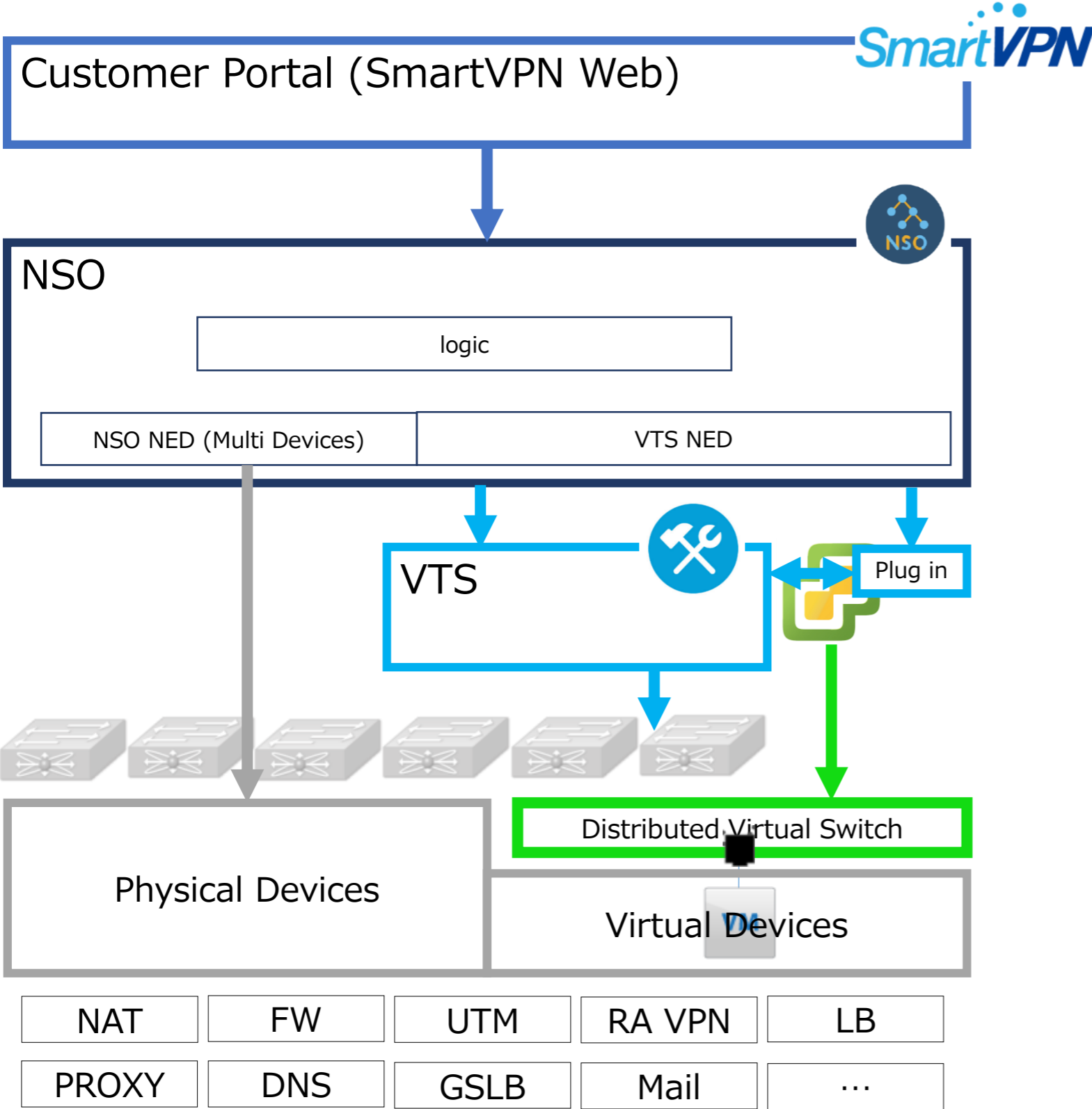



# 2 Years Operation Summary

	Before NSO	After NSO
Managed Devices	individual	about 500 devices
PNF : VNF	100 : 0	30 : 70
API Access	0 api	a few thousands api/a week
Delivery Time	1	1/3
Operation	easy	difficult

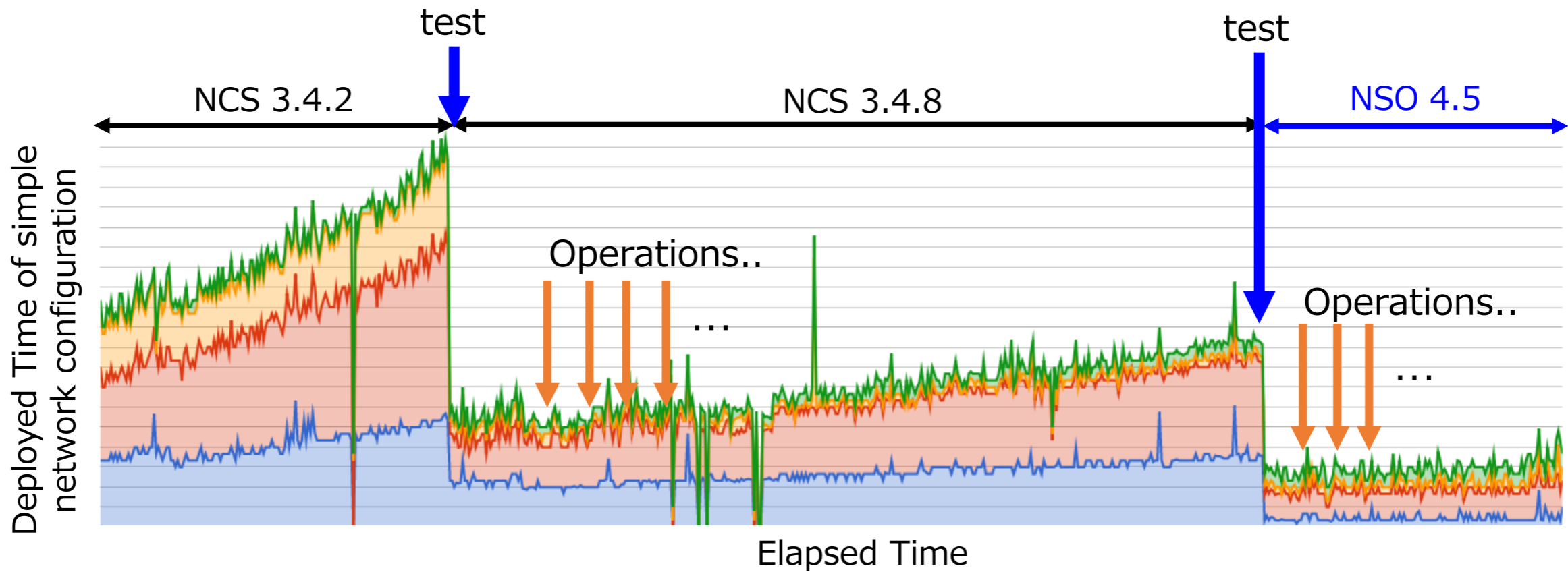

## Service Life Cycle

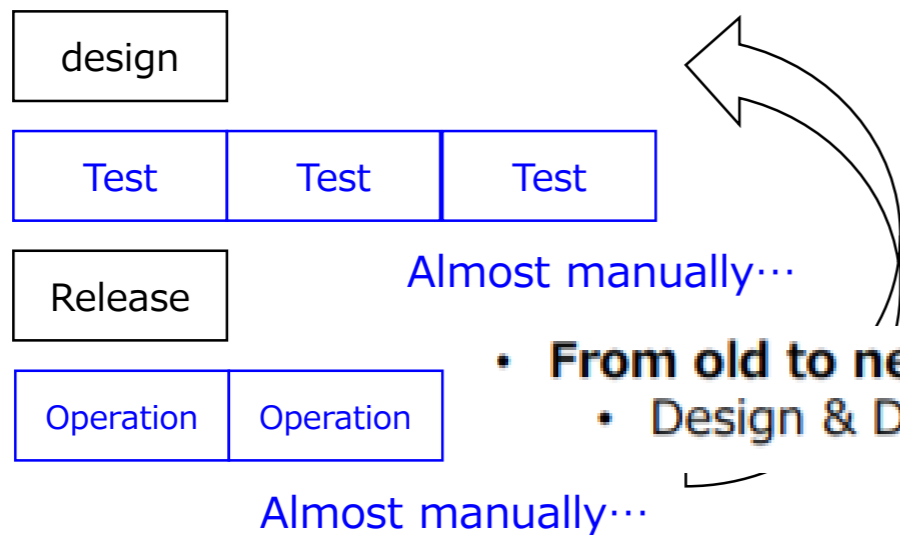

- There are many test opportunities. These need to be automated.
- network virtualization has advanced and operations have become difficult.

### • From old to new orchestrator migration

- Design & Development : 3 months
- **Test : 6 months**, Migration : 10 days

SDN/NFV World Congress 2018

# Recent Approach in Service Lifecycle

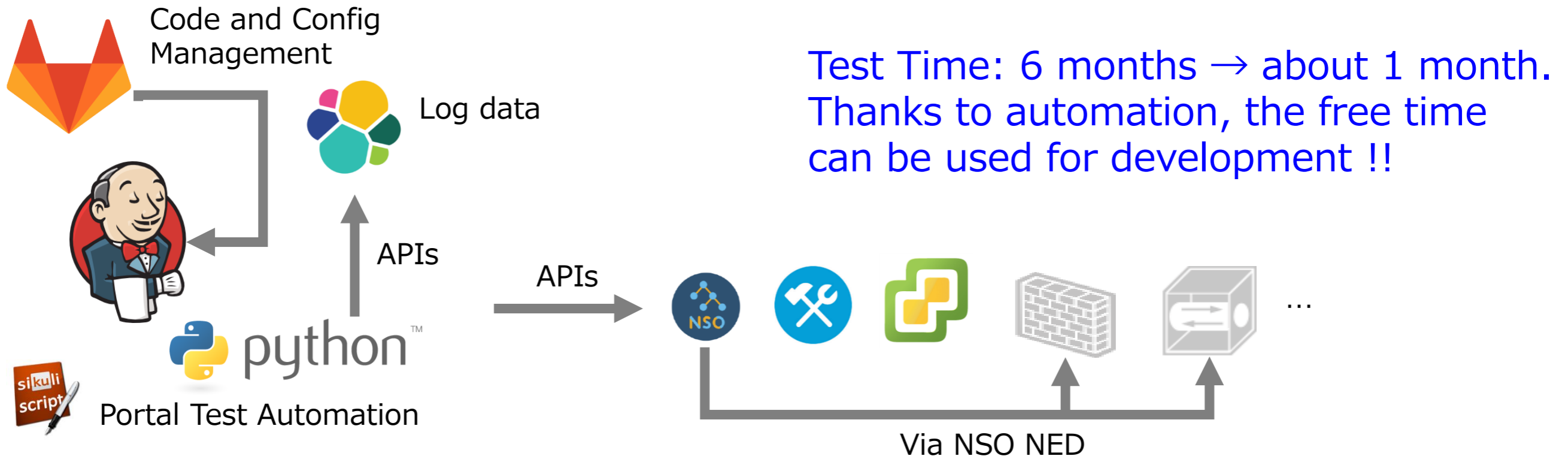

Via NSO NED

Average stage times:  
(Average full run time: ~13min 18s)

VM power on	Check Test Env	Check Basic Device Sync Status	Load merge Day 0 File	Device Sync-From	Load merge Modify File 1	Load merge Modify File 2	Initial Fetch Basic Device Configurations	Fetch Fortigate Configurations	VM power on	service config load merge	Wait
1min 28s	912ms	22s	1min 6s	4s	1min 5s	1min 5s	22s	1s	NaNy NaNd	41s	5mir
1min 29s	919ms	22s	1min 6s	3s	1min 5s	1min 5s	22s	1s	1min 29s	42s	5mir

#82  
May 30 17:14  
No Changes

	Preparation	Creating service	Test	Check Results
before	Manual			
after	Automation			Manual

# Recent Approach in Service Lifecycle

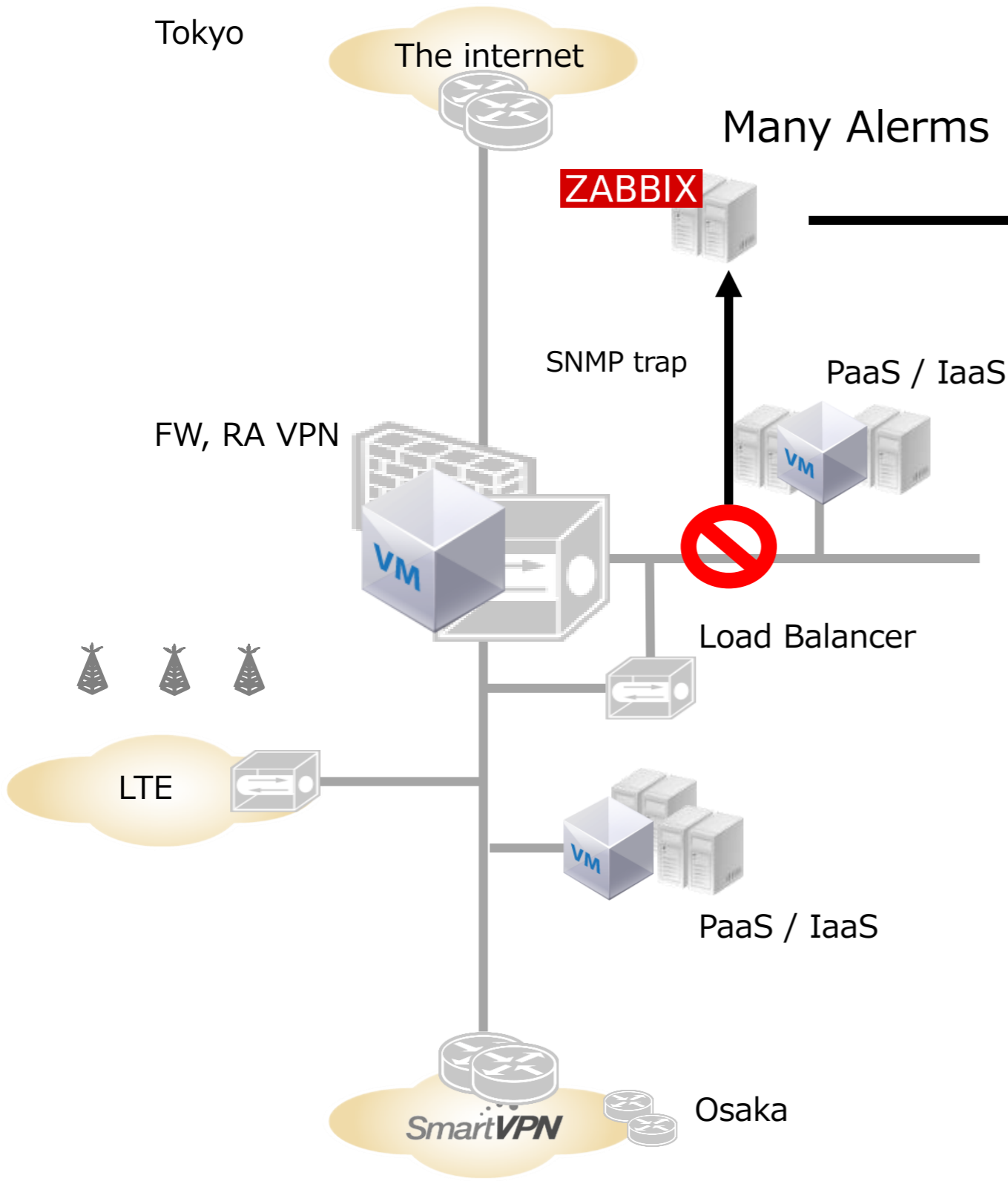

```
[4, u'Ethernet1/8 Ethernet1/8']
[4, u'Ethernet1/8 Ethernet1/8']
[12, u'Ethernet1/10 Ethernet1/10']
[12, u'Ethernet1/10 Ethernet1/10']
[12, u'Ethernet1/44 Ethernet1/44']
[12, u'Ethernet1/44 Ethernet1/44']
[12, u'Ethernet1/46 Ethernet1/46']
[12, u'Ethernet1/46 Ethernet1/46']
[16, u'Ethernet1/8 Ethernet1/8']
[16, u'Ethernet1/8 Ethernet1/8']
[28, u'Ethernet1/43 Ethernet1/43']
[28, u'Ethernet1/43 Ethernet1/43']
```

Predict failure point in a lot of alarms.



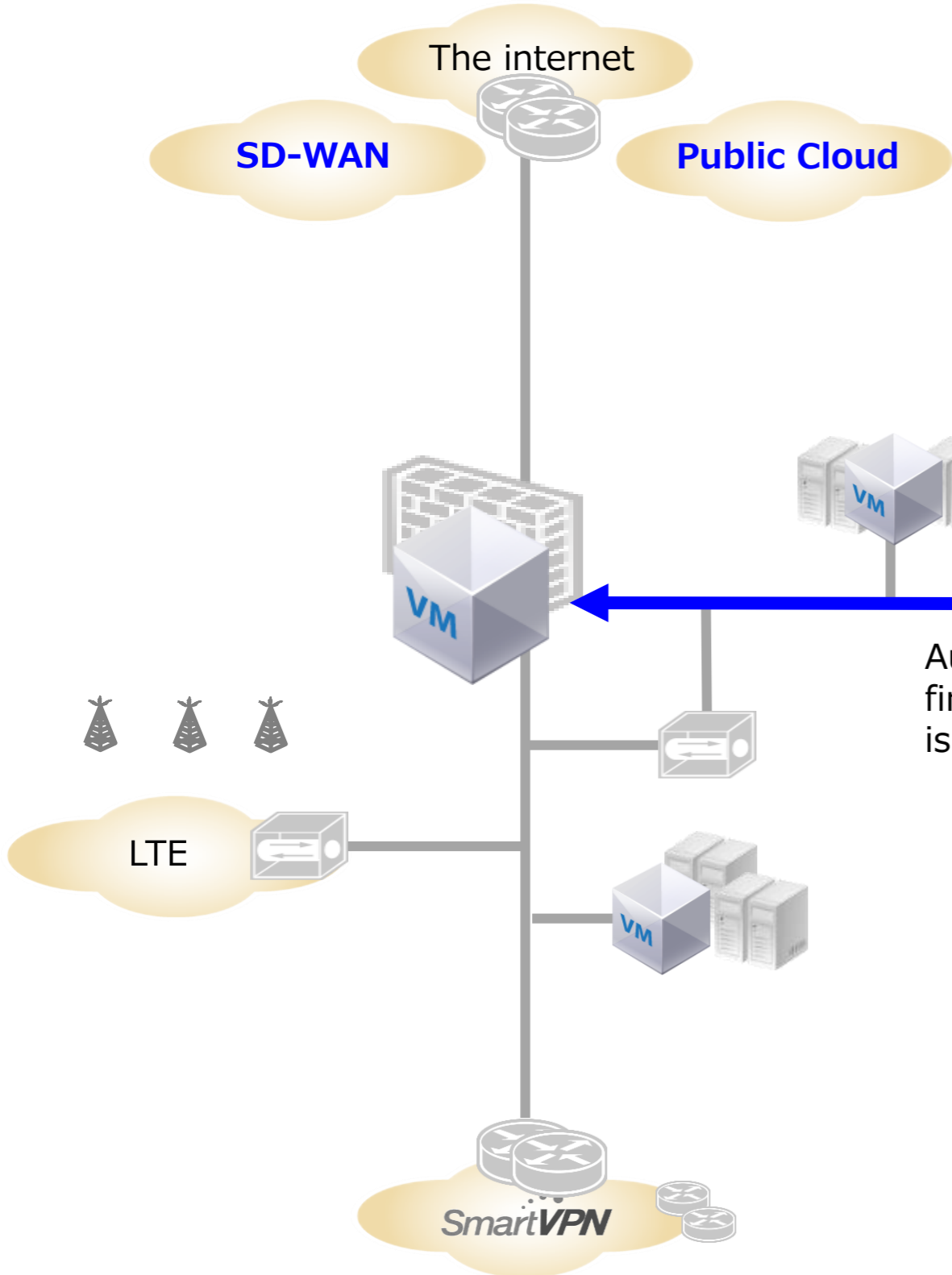

- Connection service of major public cloud service and SD-WAN via IPsec VPN
- Security service that automatically closes the firewall policy if there is a security incident

Automatically close firewall policy if there is a security incident

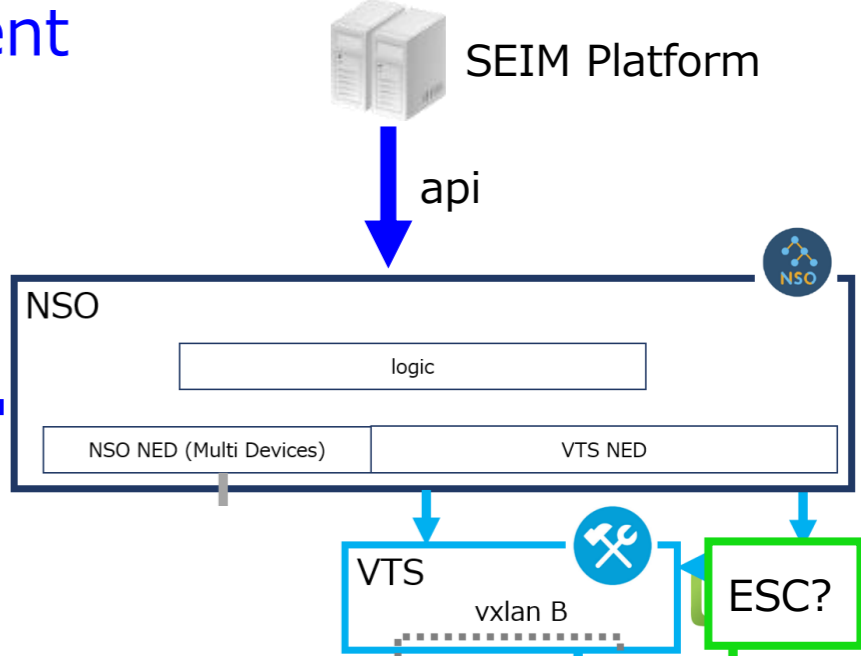

- To manage service lifecycle is important. We will consider nfv lifecycle manager such as ESC

## Service Life Cycle

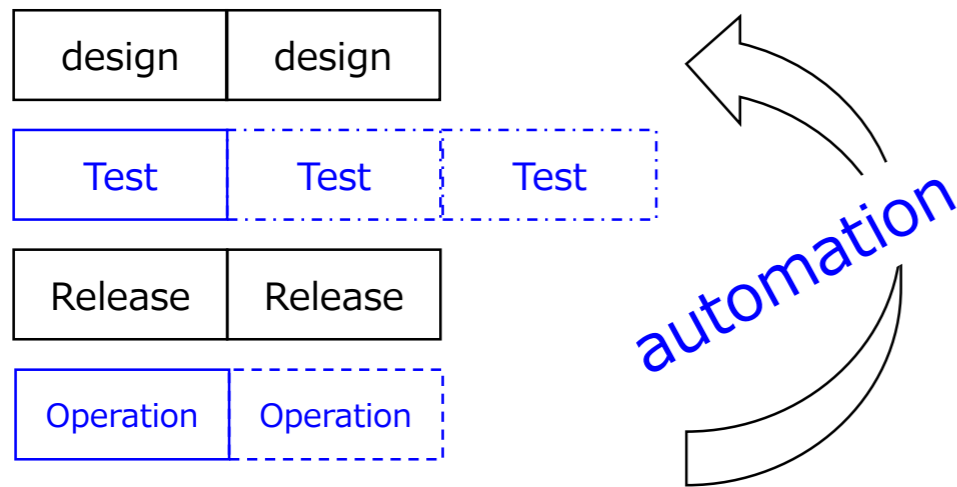

- Network orchestrator has shorter delivery times than manual.
- On the other hand, testing time to release will increase and it will be difficult to operate. As result, it takes longer to release the service.
- Automation is important to make the service life cycle fast and stable. We will continue to promote automation.

EOF