



*TOMORROW
starts here.*

Cisco *live!*



Understanding the Cisco Cloud Collaboration Platform

BRKUCC-2675

Vanessa Sulikowski

Distinguished Systems Engineer

Cisco *live!*



Understanding the Cisco Cloud Collaboration Platform

BRKUCC-2675

Vanessa Sulikowski

Distinguished Systems Engineer

Cisco *live!*

Disclaimer

The Cisco products, service or features identified in this document may not yet be available or may not be available in all areas and may be subject to change without notice. Consult your local Cisco business contact for information on the products or services available in your area. You can find additional information via Cisco's World Wide Web server at www.cisco.com. Actual performance and environmental costs of Cisco products will vary depending on individual customer configurations and conditions.



MOBILE
+
CLOUD





the most disruptive force in IT...
the end user

The Agile Worker is Transforming the Enterprise



Anytime, Anyplace
Any Device, BYOA



Stay in Constant Touch
with Team Members



Rapidly Create and Share
New Content



Cloud Collaboration Best Way to Achieve Agility....

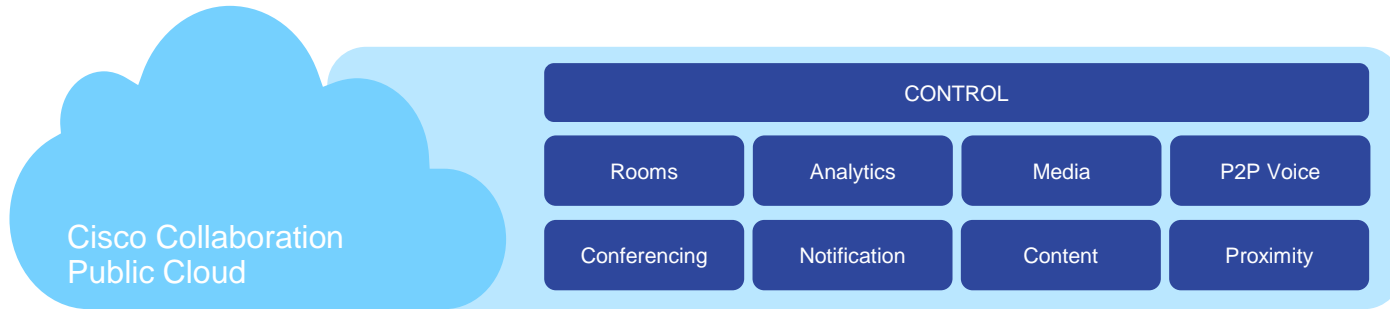

Velocity

Visibility

Versatility

Virtualisation

Collaboration Strategy

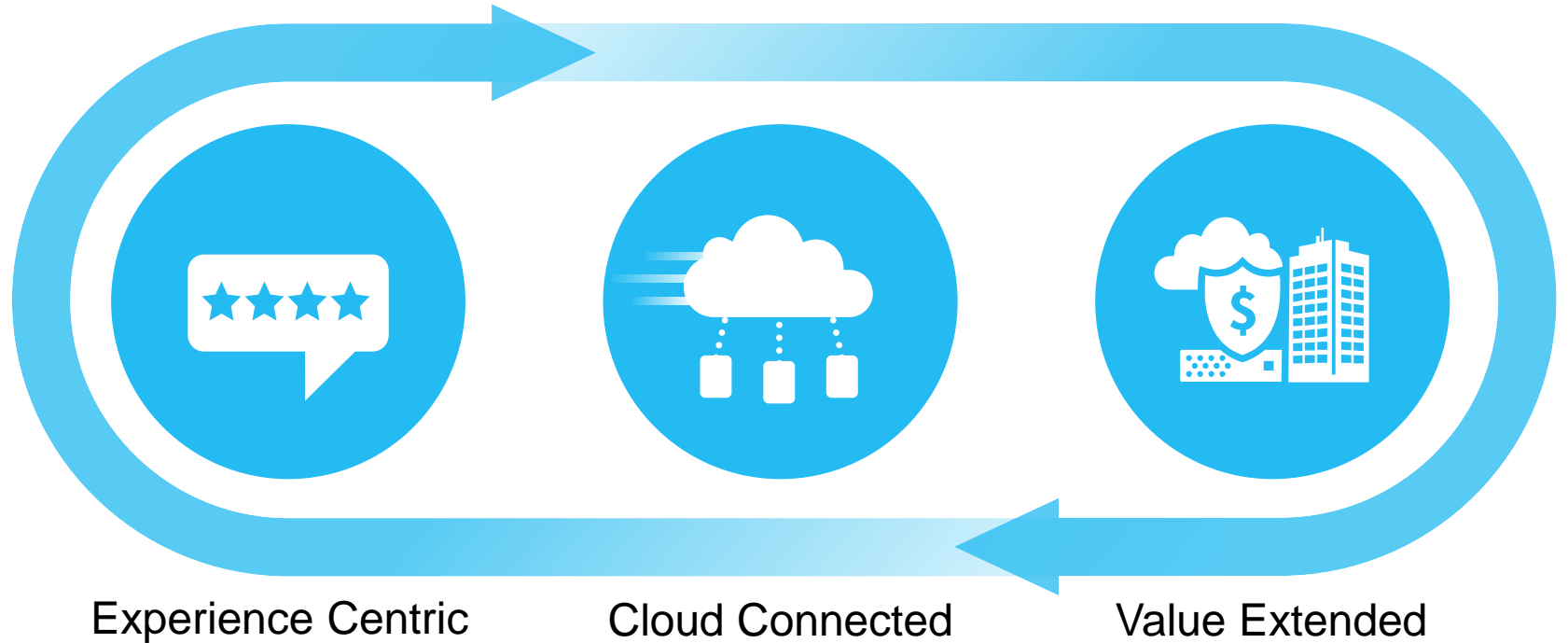

Fusion – Bringing Cloud and On-Prem Together

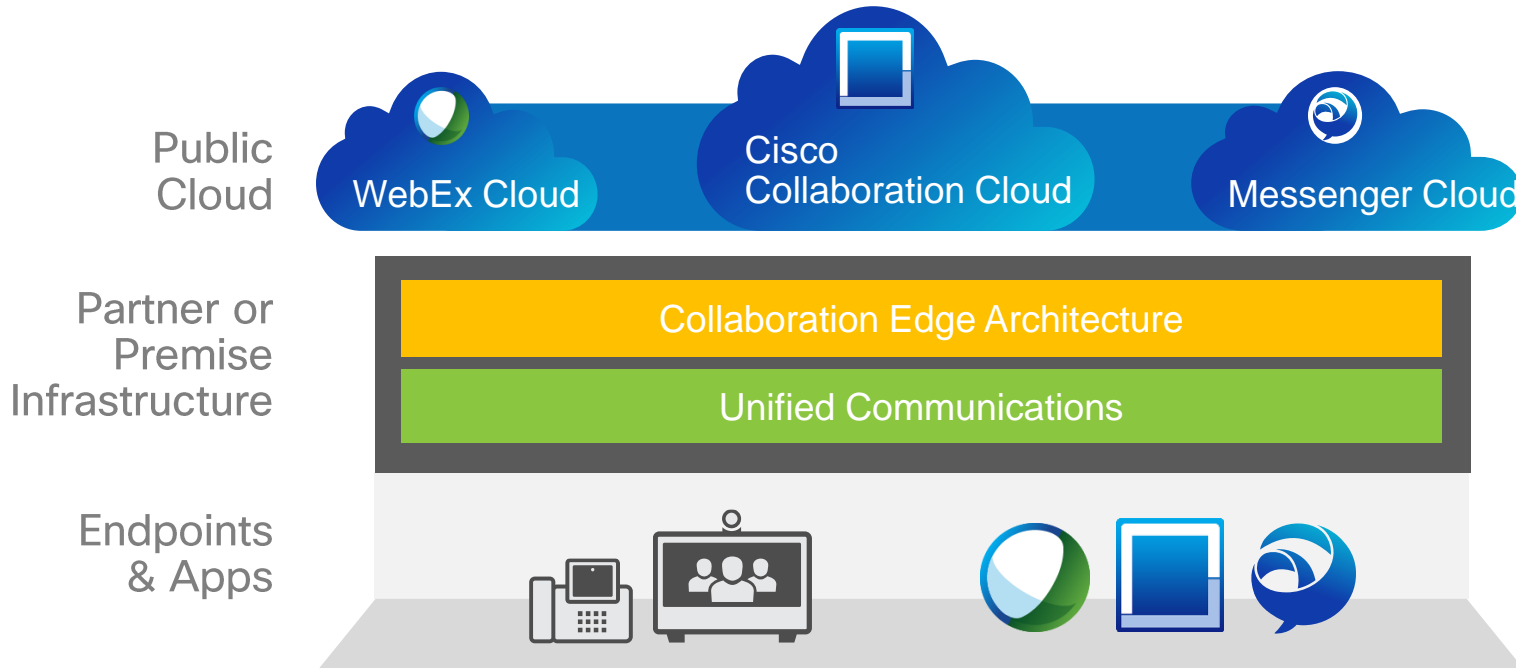



Collaboration Preferred Architecture

Preferred Architecture Deployment

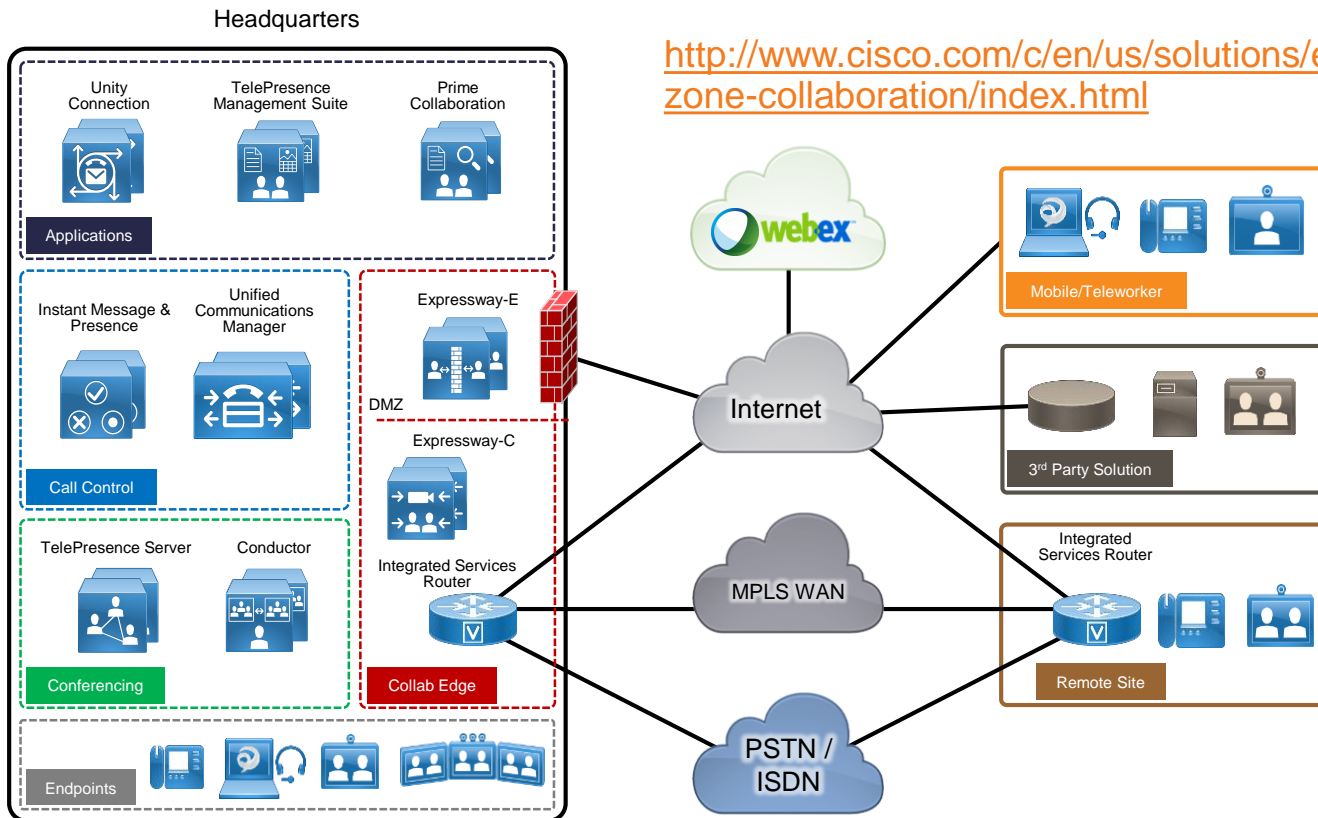

<http://www.cisco.com/c/en/us/solutions/enterprise/design-zone-collaboration/index.html>

Fusion - Existing Infrastructure Integral....

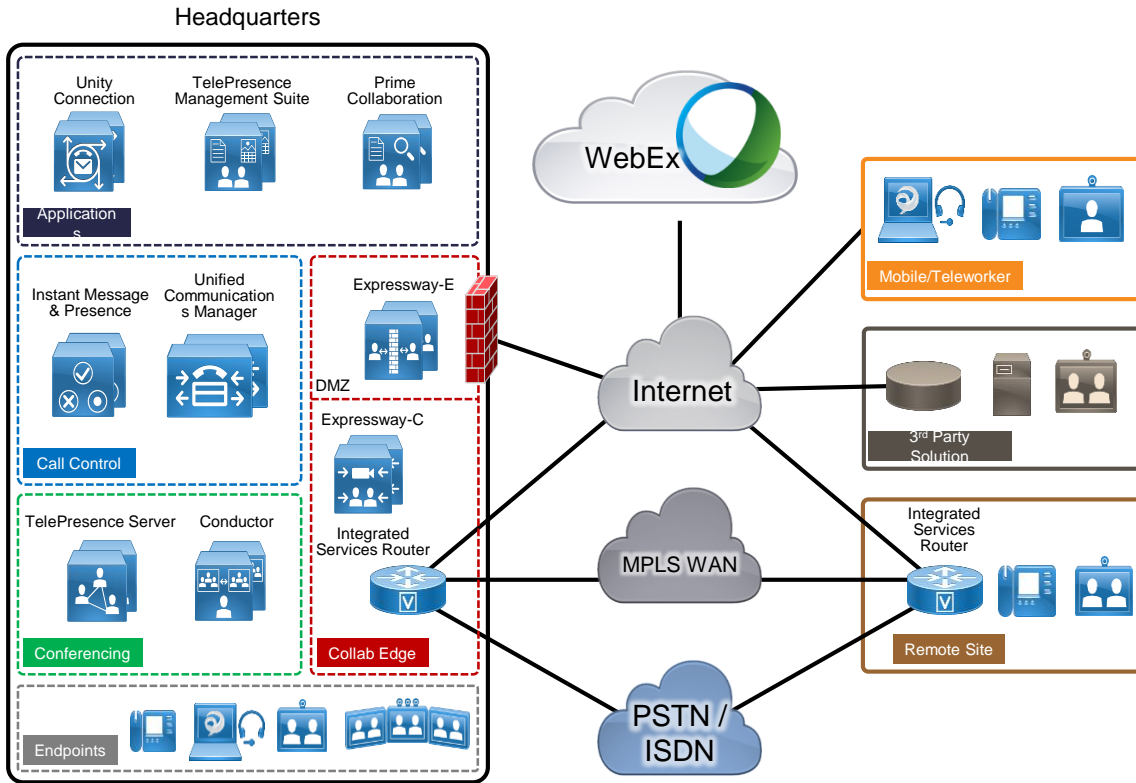

WebEx Services + IM



WebEx platform is foundational

Entitlement will carry forward

UCM, Collab Edge



UCM as our call control platform

Expressway will be key for Fusion services

Jabber / CM IM&P



Remains our premise soft client

A nighttime photograph of a city street. In the background, there are modern buildings with lit windows and a pedestrian bridge with blue lights. The middle ground shows a road with traffic lights and some blurred lights from vehicles. The foreground is dominated by long, vibrant light trails in shades of yellow, orange, and red, suggesting a long-exposure shot of light trails from traffic or perhaps a light show. The overall scene is a blend of urban architecture and dynamic light patterns.

Cloud Collaboration Platform

Cisco Collaboration Cloud



Iteration

Continuous delivery
Software Platform



Fusion

Ties together today's
core collaboration
products with cloud



Security

User messaging and
content encrypted in
transit and at rest



Ecosystem

Partners, developers
& administrators as
first class citizens

Cisco WebEx Cloud (the cisco cloud you already know)

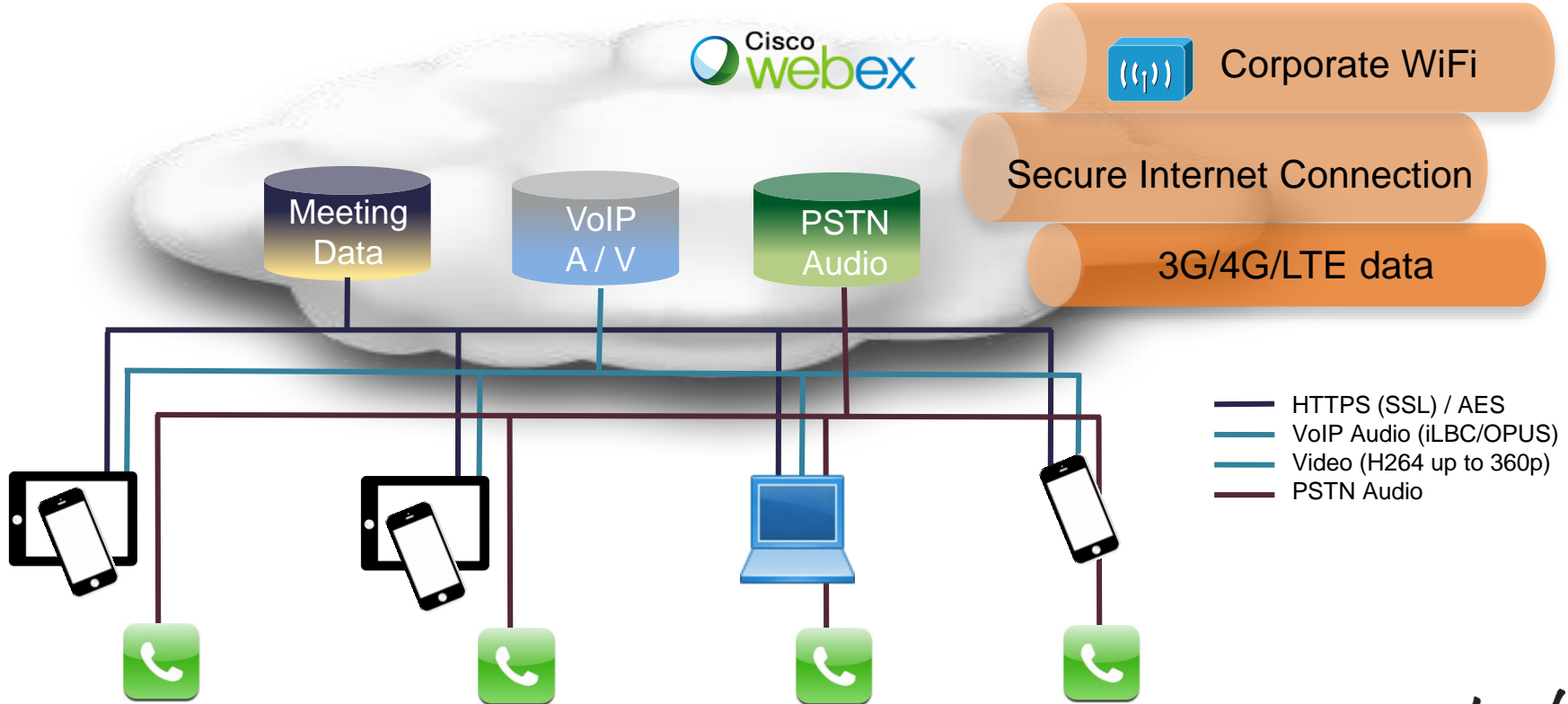

Cisco Collaboration Cloud

PaaS/IaaS – OpenStack, Cloud native delivery

Using Cisco Intercloud deployment

Integrating with Existing services
(WebEx Meetings, Identity, Messenger)

Continuous, Consistent & Rapid
Deployment

Scale-out local/multi data centre

Geographic reach & resiliency
(Active – Active)

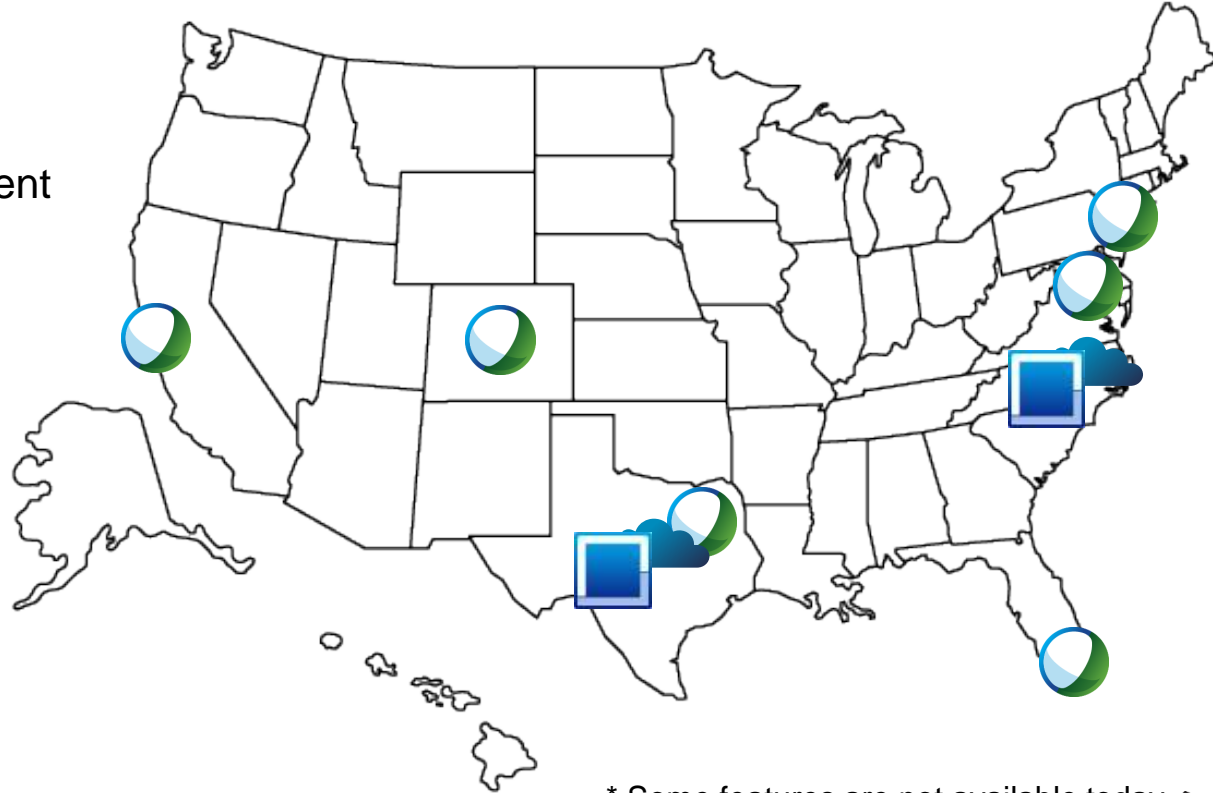

* Some features are not available today

Cisco *live!*

The Cisco Collaboration Cloud

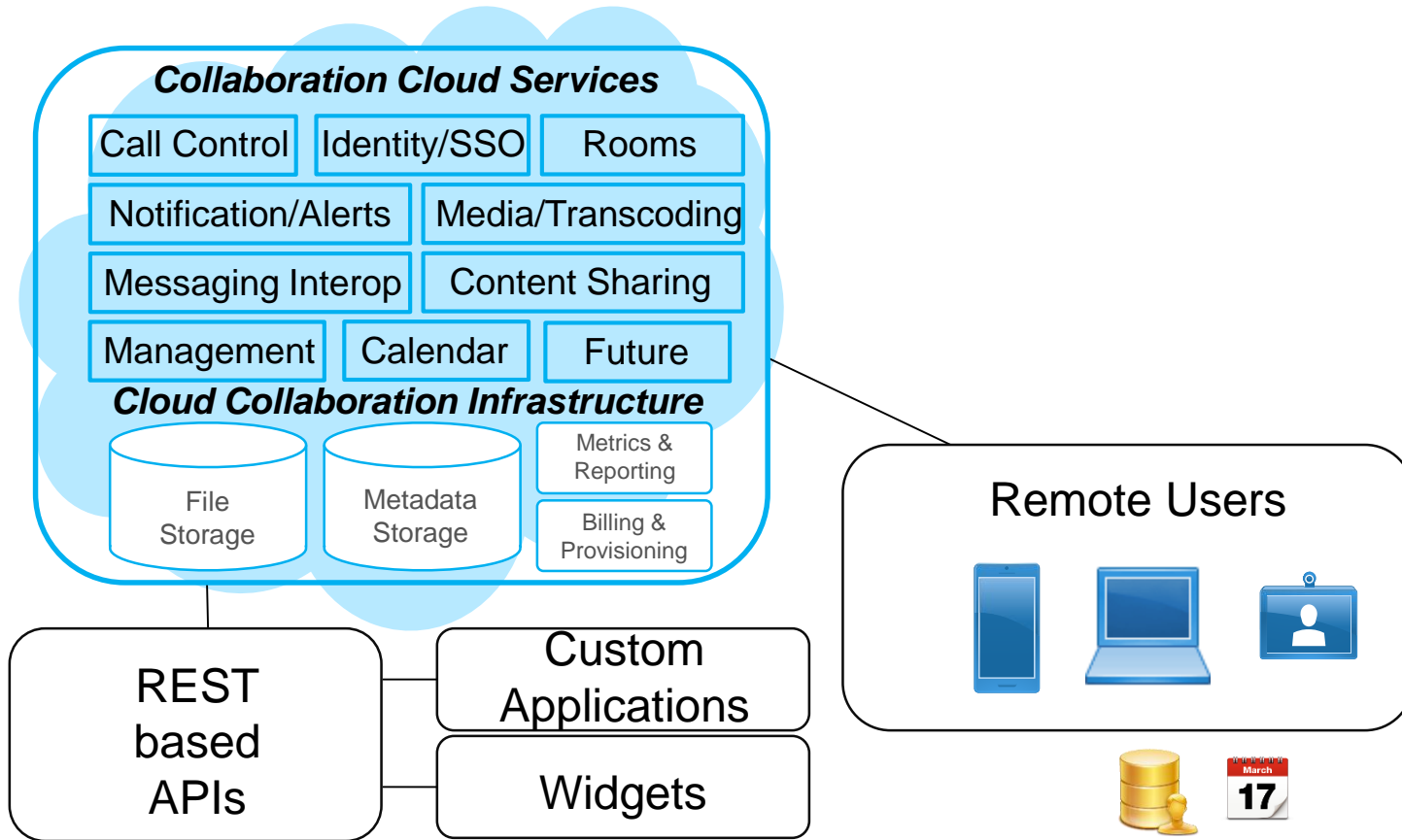

Cisco Collaboration Cloud

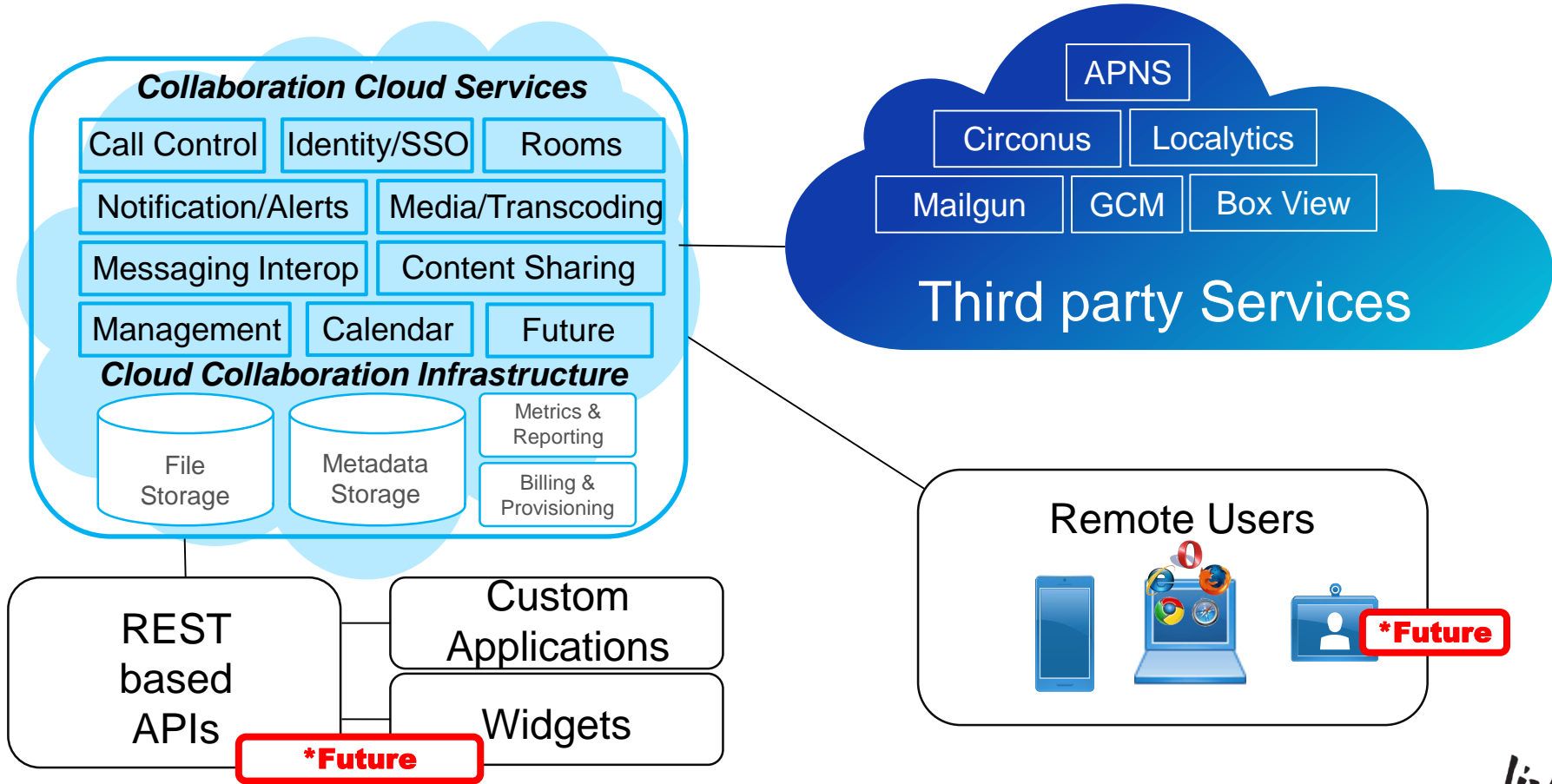

Cisco Collaboration Cloud Architecture

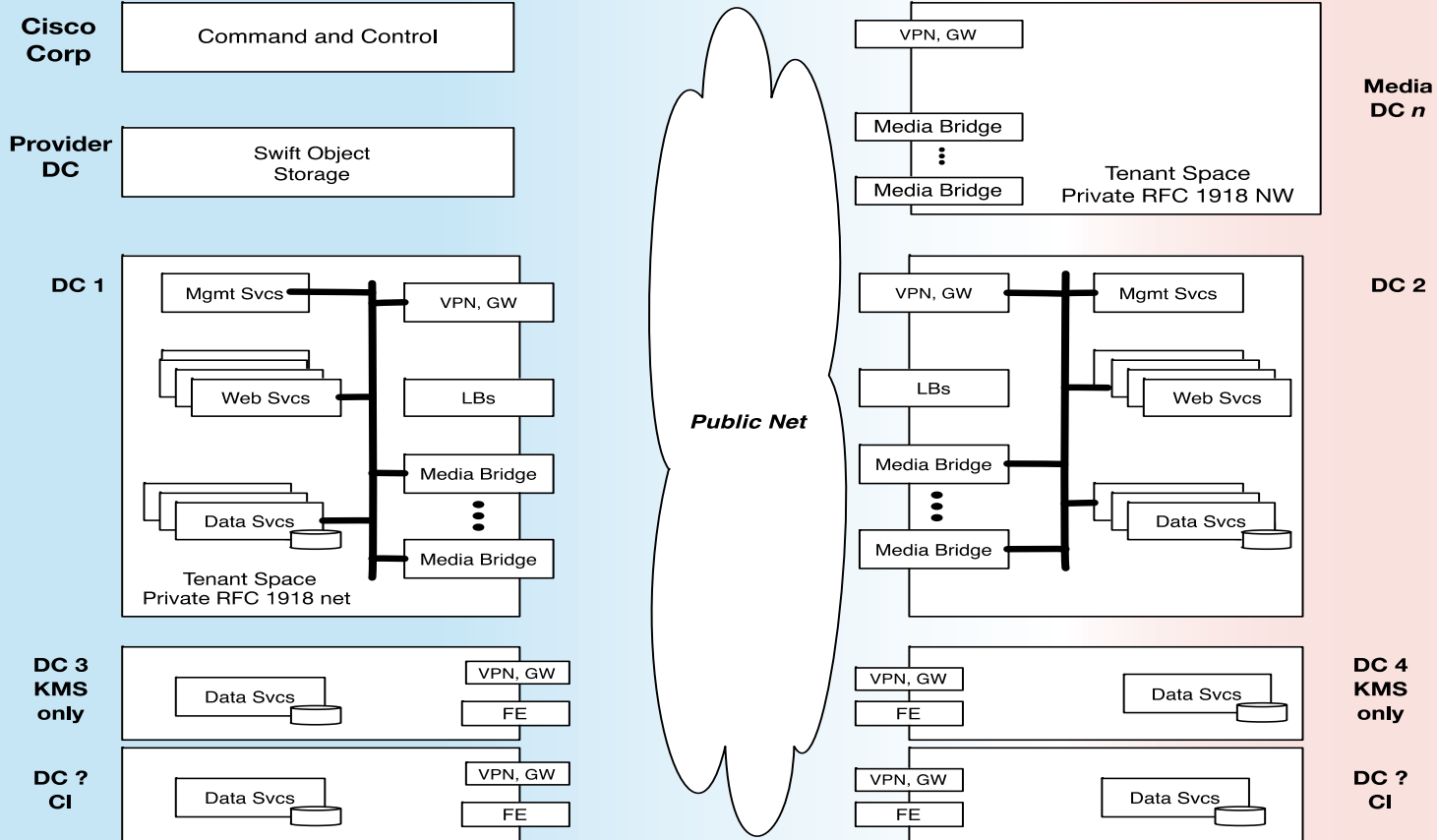

Generally Available in North America and select markets

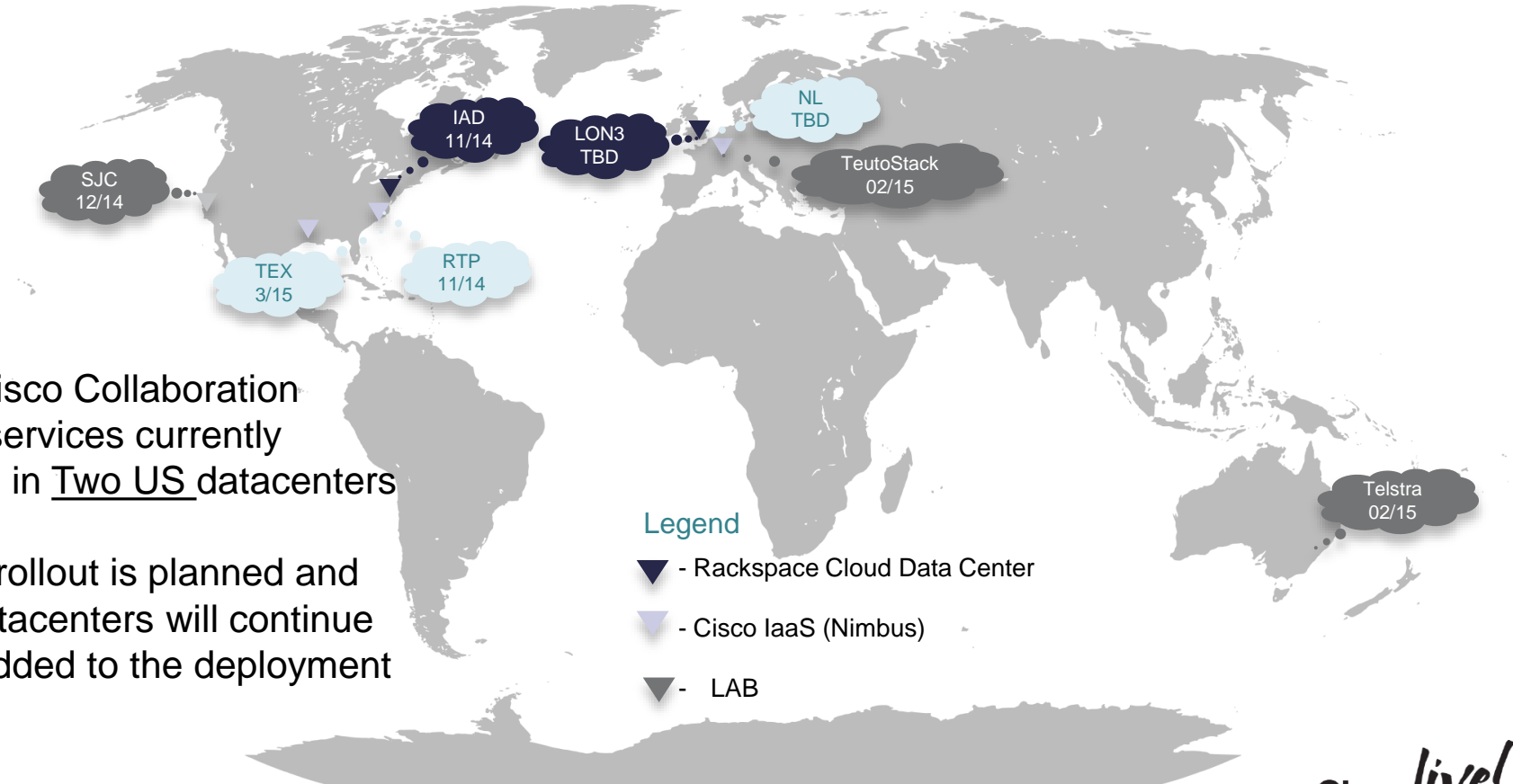

Core Cisco Collaboration Cloud services currently running in Two US datacenters

Global rollout is planned and new datacenters will continue to be added to the deployment

Cisco Collaboration Cloud Solution – Common Identity

(WebEx will migrate to Common Identity in T30/T31 release)

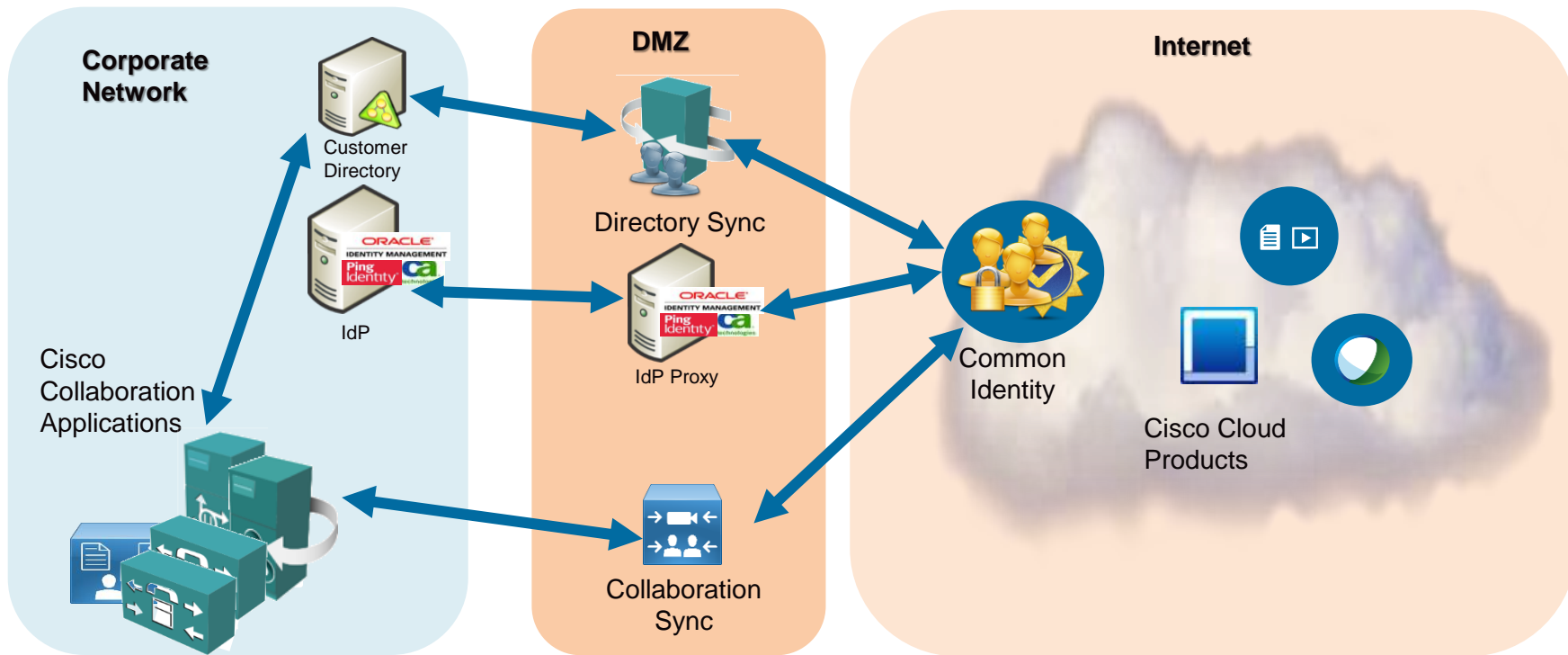

Cisco Collaboration Cloud Security - Overall Approach

- Obfuscation of user identity as widely as possible
- End-to-end encryption of messages and content
- Granular access control
- Flexibility of data storage locations

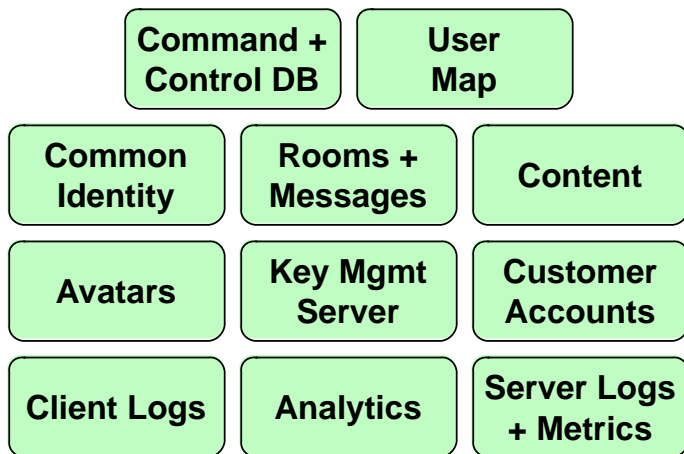

Cisco Collaboration Cloud Security

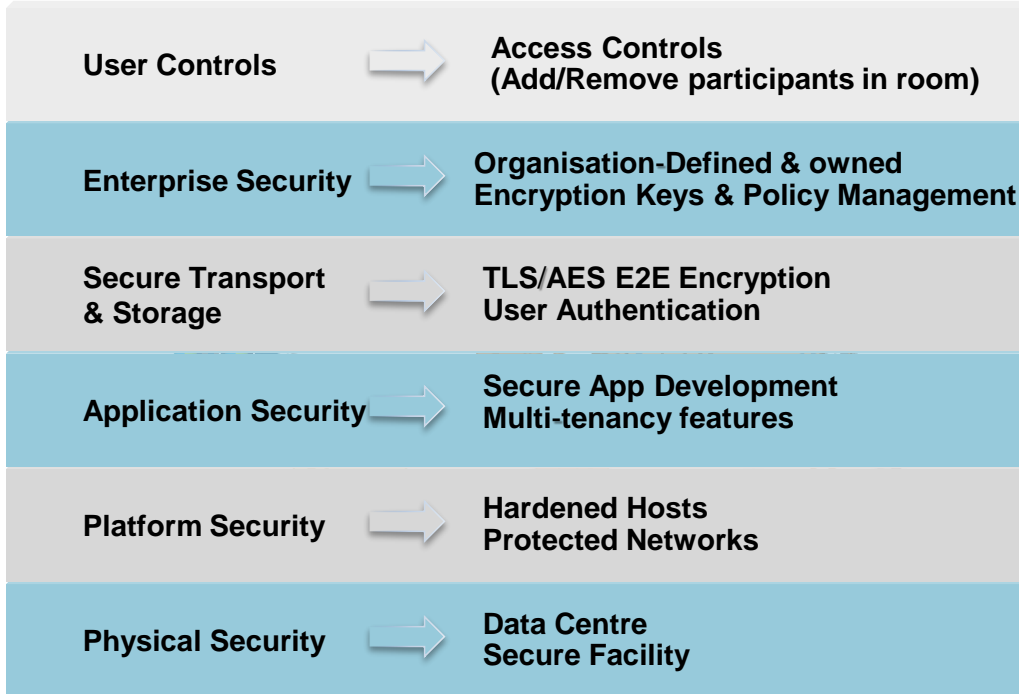

Enterprise Grade Security
is IMPORTANT!

- Privacy & security of communication with E2E encryption
- Protecting intellectual property
- Preventing unauthorised communication
- Supervising and monitoring content, ethical walls*
- Compliance with legal discovery*

Enterprise Grade Security – High Level

Data in motion encryption:

Encrypted signalling audio/video

HTTPS

Encrypted Media (sRTP/SRTP-EKT)

Data at rest (Persistent Storage)

Separate DB Stores KMS/Content

Stored Content – always fully encrypted

End-To-End Encryption with AES-256GCM symmetric key:

Ephemeral Keys - rotation

Encrypted Messaging

Encrypted Content

Encrypted Room Titles

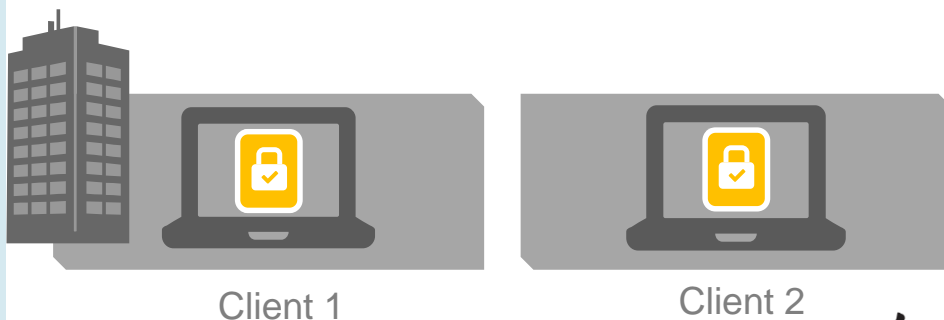
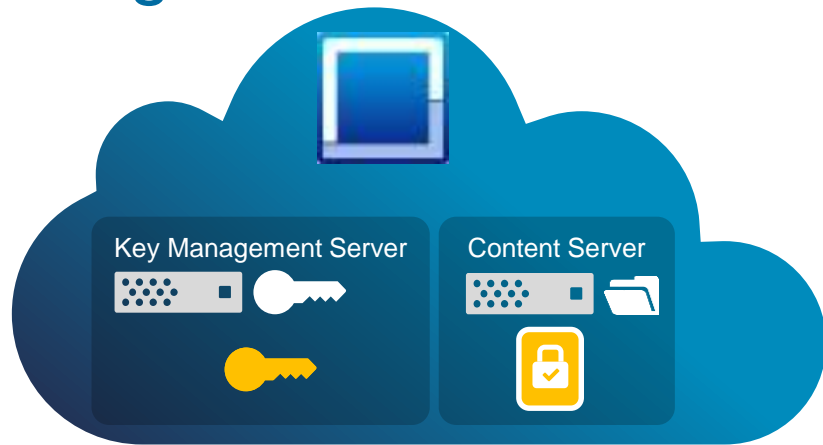

Enterprise Grade Security – Key Rotation

- Key Management Server (KMS) manages keys.
- Signed ephemeral Elliptic curve Diffie–Hellman key exchange between client and KMS.
- KMS generates conversation keys and distributes them to conversation parties.
- Parties encrypt all payloads using AES-256. *(envelope is unencrypted)*
- “Squared” servers route based on the envelope.
- “Squared” servers archive everything *(in encrypted form)*

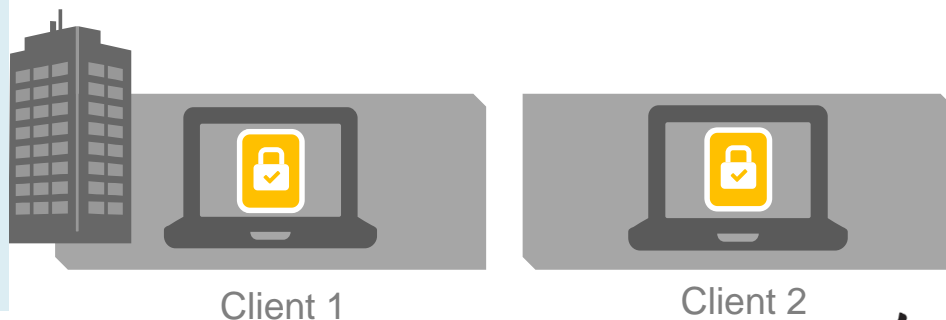
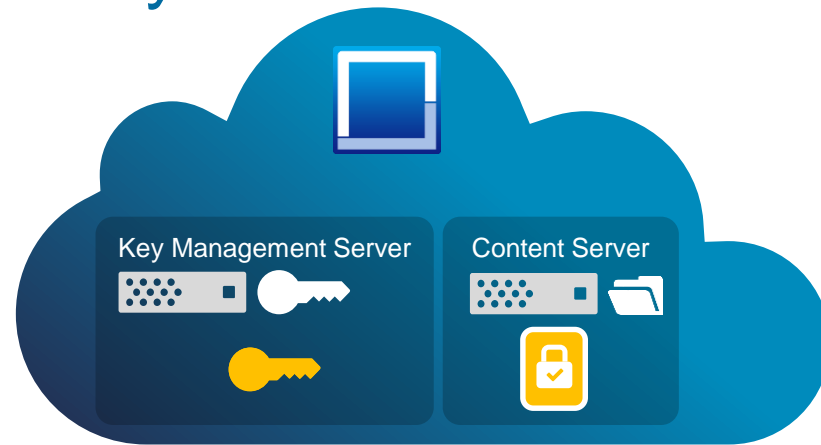

Key Management Service Architecture

<https://tools.ietf.org/html/draft-abiggs-saag-key-management-service-00>

A nighttime photograph of a city street. In the foreground, there are long, curved light trails from cars, primarily in shades of yellow and orange. In the middle ground, a pedestrian bridge with a glass railing spans across the street. The background features several modern buildings with lit windows and some flags on poles. The overall scene is illuminated by city lights, creating a vibrant urban atmosphere.

Cisco Spark Team Collaboration

(Formerly known as Project "Squared")



This is how we worked.

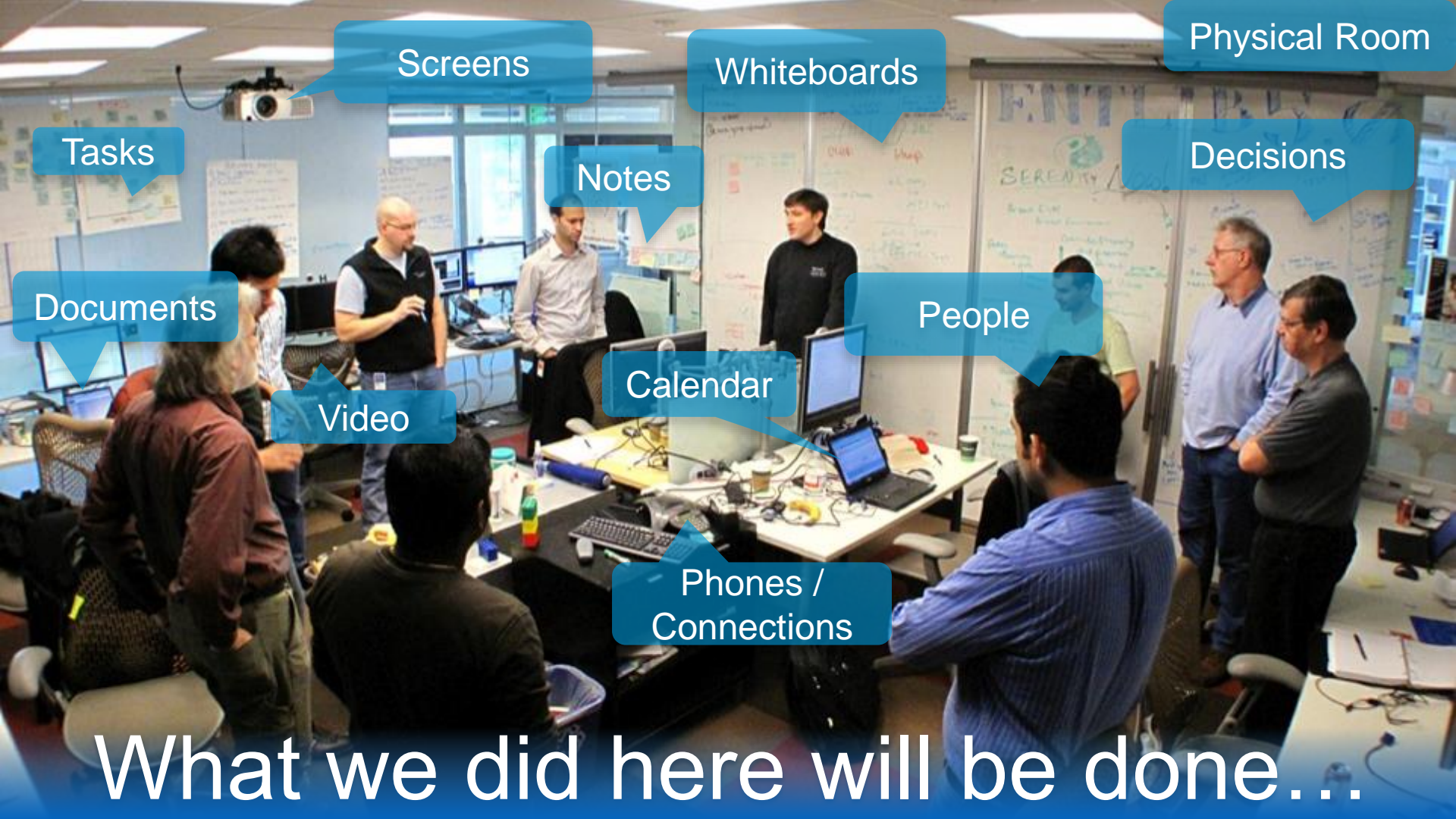

Screens

Whiteboards

Physical Room

Tasks

Notes

Decisions

Documents

People

Video

Calendar

Phones /
Connections

What we did here will be done...

Welcome to the place
where your team works

Rooms

Screens /
Sharing

Voice/Video

Notes /
Discussion

People

Documents

Here...

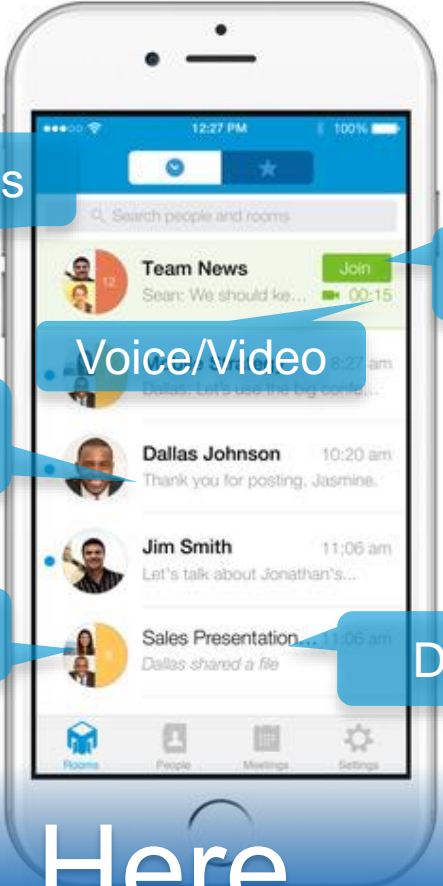

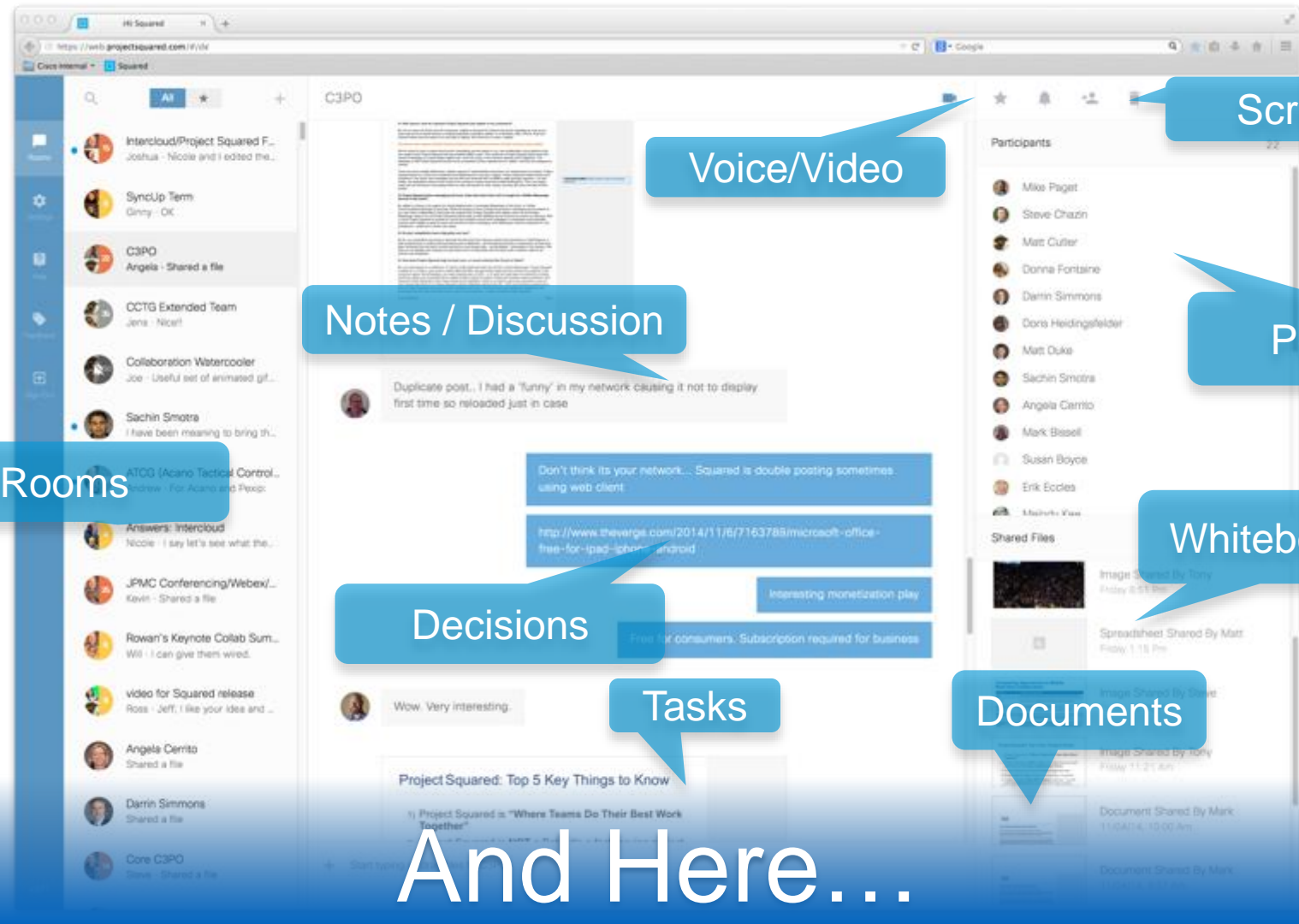

Screens

Voice/Video

Notes / Discussion

People

Rooms

Whiteboards

Decisions

Tasks

Documents

And Here...

Introducing Cisco Spark

Delivered from the Cisco Collaboration Cloud

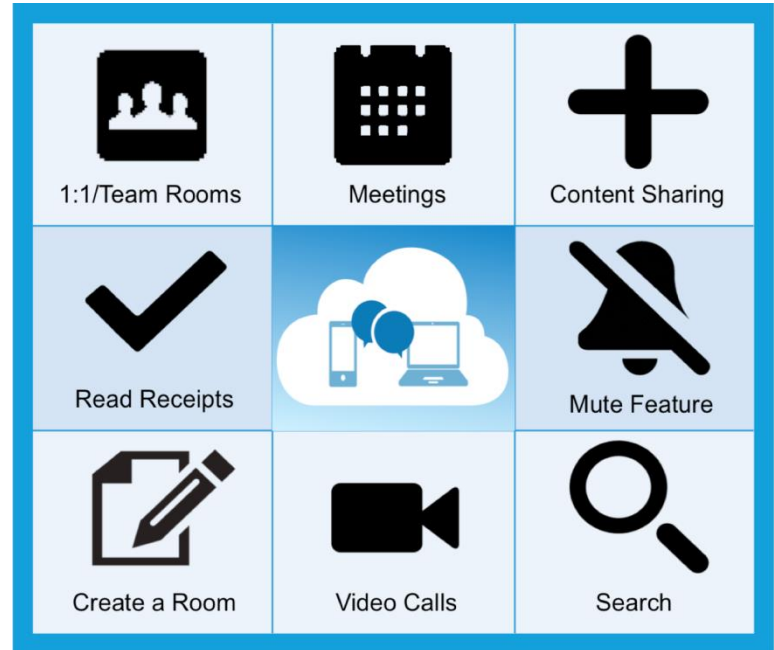
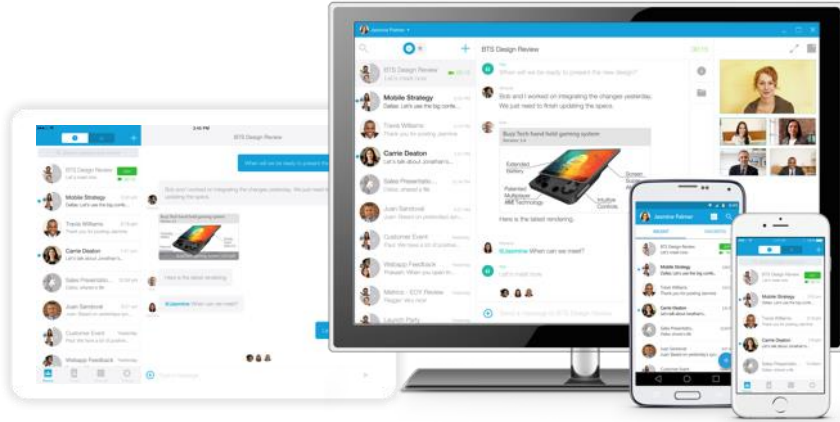

<http://download.ciscospark.com>

Cisco Spark: Work from Anywhere

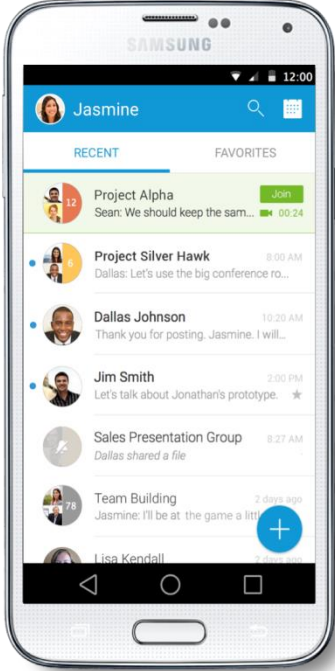
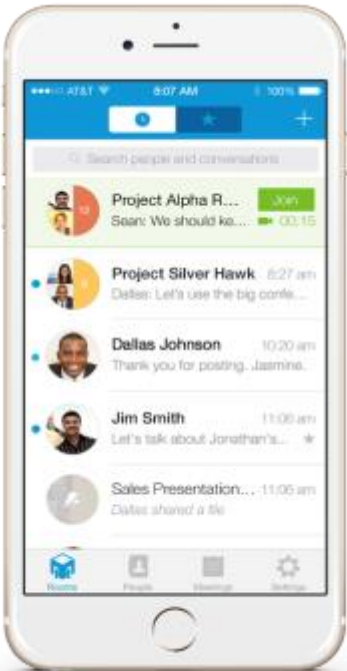

Cisco Spark: Use the interface you have at hand...

Virtual Rooms for Everyone

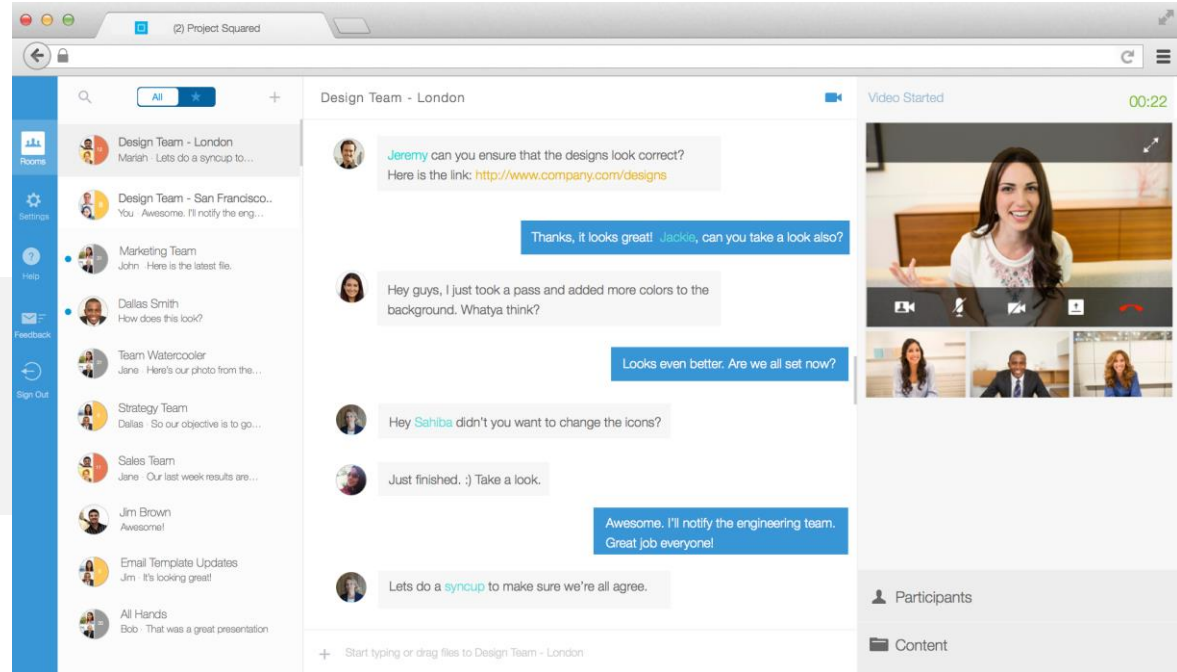

Cisco Spark and WebEx integration - Meetings

- Project Squared Client x-launch WebEx app
- Create Room from Calendar “Slurp”

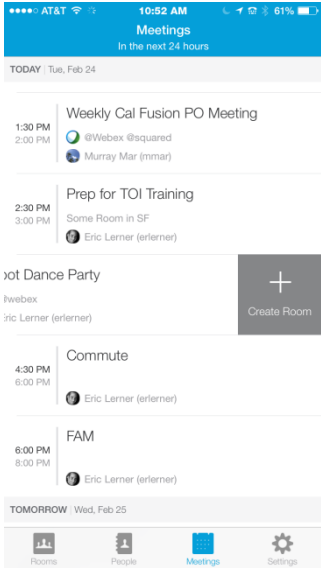
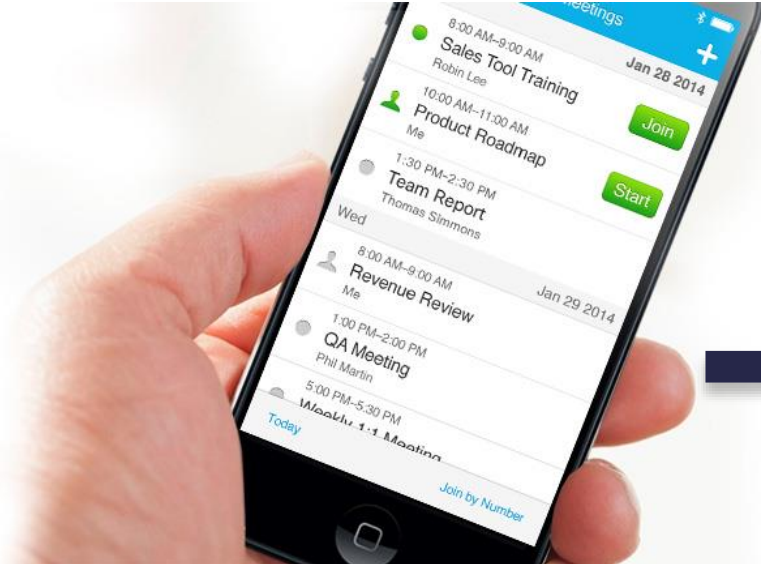

System Requirements

- iOS: Requires iOS 7.1 or later. Compatible with iPhone, iPad, and iPod touch. This app is optimised for iPhone 5, iPhone 6, and iPhone 6 Plus.
- Android: Requires 4.0.3 and above (Tablets not optimised, but working)
- Mac Client: Mac OSX 10.9 or higher
- Windows Client: Windows 7 or 8 (Windows Phone N/A for March GA)
- No admin rights required for install after March GA (Mac/Win)
- Web:

Chrome: Latest two versions supported

Internet Explorer: 10 and above (know issues with IE11)

Safari: Latest two versions supported

Firefox: Latest two versions supported (minimum version 33.1)

Recommended for the full video experience (WebRTC support)



Check for the latest requirements @ <https://support.ciscospark.com/>

Cisco *live!*

Global* General Availability of Cisco Spark



Client & Admin Portal Localisation

- Chinese (Simplified)
- Chinese (Traditional)
- Czech
- Danish
- Dutch
- English
- English (UK)
- Finnish
- French
- German
- Italian
- Japanese
- Korean
- Norwegian
- Polish
- Portuguese (Brazilian)
- Spanish (Latin America)
- Spanish (Spain)
- Swedish
- Turkish



Online Support Localisation

- Chinese (Simplified and Traditional)
- English (US)
- French
- German
- Japanese
- Korean
- Spanish (Latin America)

* Available for March 18th, 2015 GA:

Australia, Canada, Denmark, France, Germany, Mexico, Netherlands, Norway, Poland, Spain, Sweden, Switzerland, UK, USA,



Cisco *live!*

Recommended Firewall Ports Settings

Consider UDP over TCP traffic

Functionality	Protocol	Port
Messaging	HTTPS	443
Notification	WSS	443
Call	HTTPS	443
Media (non-shared port)	RTP/SRTP over UDP	33434 - 33598 8000-8100
Media (non-shared port)	RTP/SRTP over TCP	33434 - 33598 8000-8100
Media (shared port)	RTP/SRTP over UDP	33434
Media (shared port)	RTP/SRTP over TCP	33434

Note: No proxy support in March GA time frame

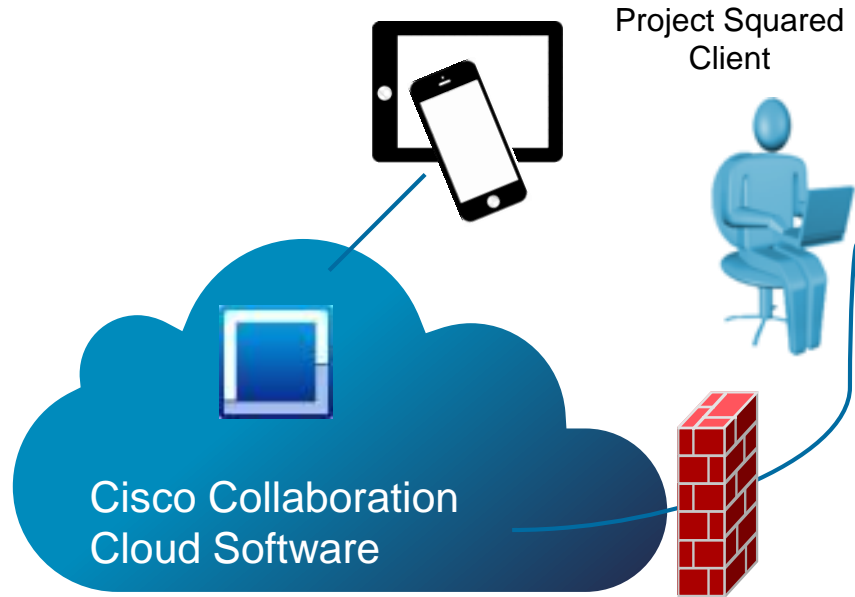

Single shared media port deployment with “ICE”

Use single port #33434 which is within existing dynamic range customers have enabled.

Media/Share go through that port. Tries UDP and falls back to TCP if needed.

Preliminary Average Bandwidth Utilisation

	Audio	Video	Share
Codec	Opus	H264	H264
Mobile	50kbps capped at 64kbps max	360p @30fps max resolution 700kbps capped at 1.0 Mbps max	1080p @5fps max 150kbps-1.5Mbps max depending on content
Desktop	50kbps 150 kbps for Mac/ Win Receive (local mixing with top 3 participants)	720p @30fps max resolution 1.5Mbps capped at 1.5 Mbps max Note: During poor network conditions, the video stream may be disabled	1080p @5fps max 150kbps-1.5Mbps max depending on content

Project Squared is using optimised WME, bandwidth profile is similar to WebEx client experience in CMR type meeting. Currently only desktop sharing is supported (no annotation or application sharing), Audio codec supported with WME is Opus

Cisco Spark User Account Management Options

Option	Description
Manual through Org Admin	<ul style="list-style-type: none">• Admin can use Org Admin to manually create/update user accounts
User Invite (side-board)	<ul style="list-style-type: none">• Cisco Spark User can invite another user to use Cisco Spark
Directory Integration MSFT 2003/2008 R2 supported	<ul style="list-style-type: none">• automatic method for creating, updating and deactivating user accounts and groups.• Customer or Partner enables AD integration via Admin Portal
Single Sign-On	<ul style="list-style-type: none">• SSO can be configured to automatically create account with AD integration or simply to be used for authentication only• SP initiated integration only (no IdP initiated support)

Note: For March GA user administration and management must be done in two places, WebEx user integration in Admin portal scheduled in T30 release.

Cisco Spark User Provisioning

Manual or Directory Integration & Sync

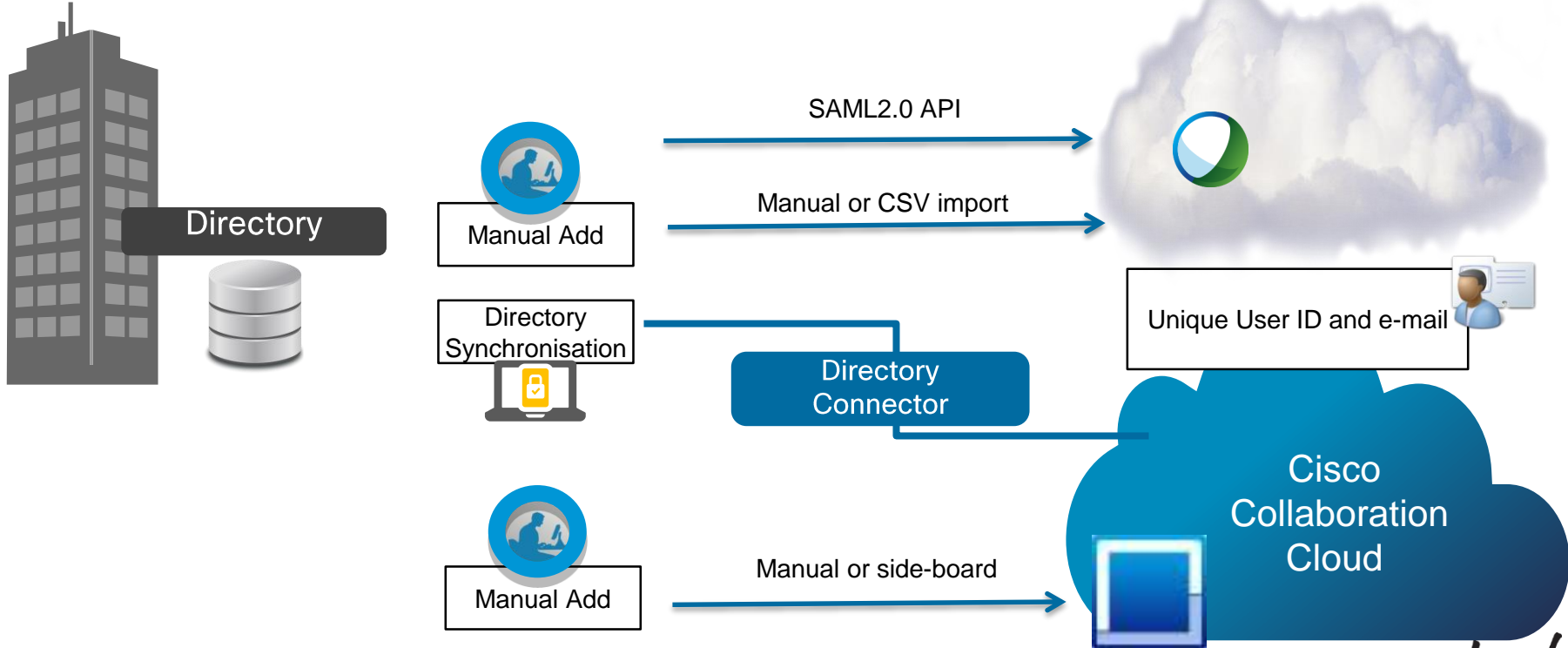



Cisco Spark Demo

A long-exposure photograph of a city street at night. The foreground is dominated by vibrant, multi-colored light trails from moving vehicles, creating a sense of motion and energy. In the middle ground, a modern pedestrian bridge with a glass railing spans across the street. The background features several tall, illuminated buildings, some with distinctive architectural details like balconies and windows. The overall scene is a dynamic and modern urban environment.

Administration Portal

Management Portal

Single Pane of Glass for Partners and IT Administrators

First Name	Last Name	Email	Status	Actions
Andy	Steele	andys@companymail.com	Active	...
Olivia	Smith	osmith@companymail.com	Invite Pending	...
John	McKenzie	mbrown@companymail.com	Invite Pending	...
Vichai	Iamsiri	viamsiri@companymail.com	Active	...
Karolyn	Bachelor	kbachelor@companymail.com	Active	...
Sam	Anderson	sanderson@companymail.com	Active	...
Javier	Carbajal	jcarbajal@companymail.com	Active	...
Tommy	Wright	twright@companymail.com	Active	...
Andy	Steele	andys@companymail.com	Active	...

- Easy User Onboarding
- Enterprise Single Sign-on
- Sync with On-Premise Directory Service
- Role Based Access
- Analytics & Metrics
- User, Group & License Management
- **Partners:** Simply Launch Trials and Manage Accounts

Admin Portal – Landing Page (Partner) <https://admin.ciscopark.com>

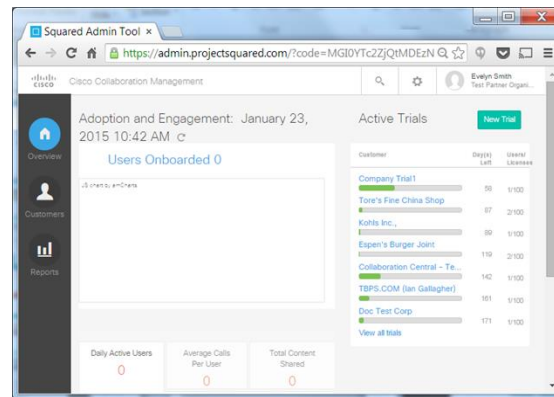
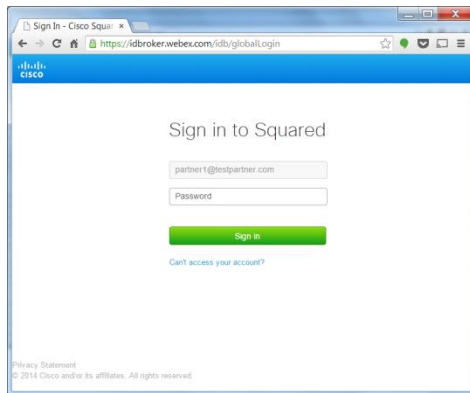
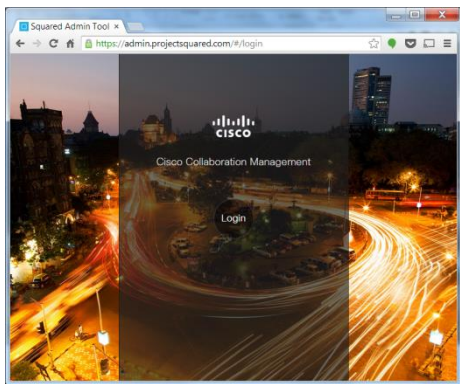

Partner

Access Customer Admin Console

Starting a Project Squared Trial for Customer

Reviewing/Modifying Customer's Info

Manage Customer Trial or Provide Site Administration Service

Admin Portal – Landing Page (Org Admin) <https://admin.ciscopark.com>

Customer Admin Console
Create Project Squared Account
Status Page Quick Access
SSO configuration
Reports & Analytics
Support & Logs

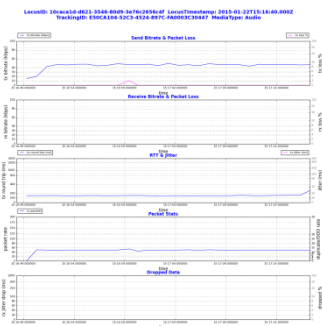
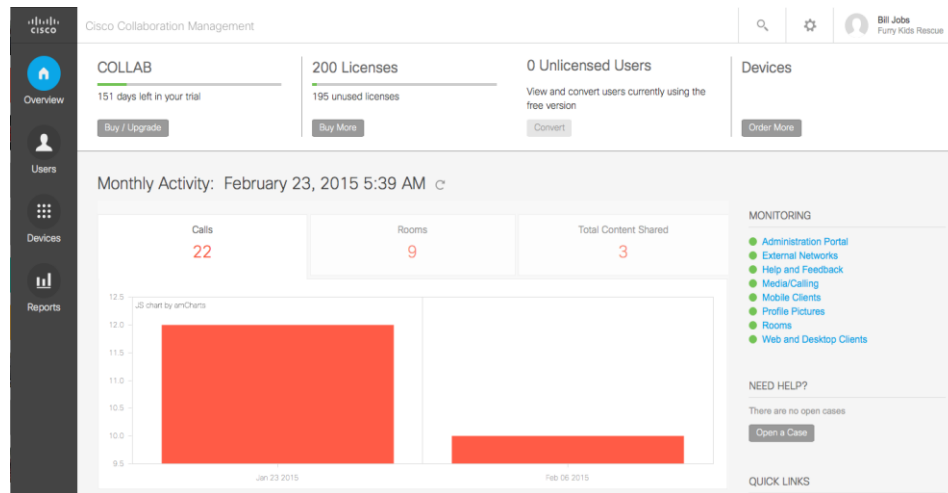
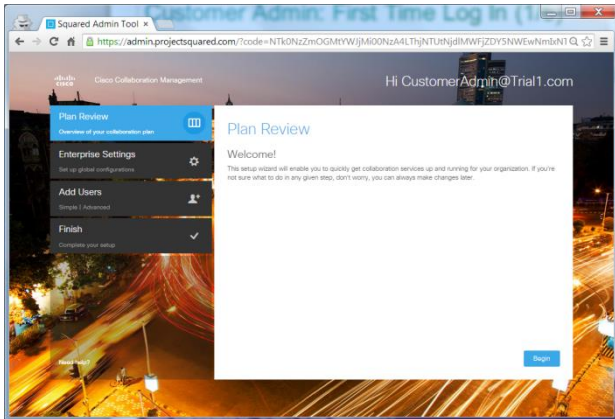

```
[CheckingAudio_statsfound: times=02]
parsing order in file stptime:
/usr/local/tools/debug-tools/integration_tool_w/wr/temp/logs.txt 1978-01-17 11:40:09.058893
/usr/local/tools/debug-tools/integration_tool_w/wr/temp/logs.txt
Error in timestamp format: [Audio][Video][ScreenShare] cid_114 this=812f2f280

parsing order in file stptime:
/usr/local/tools/debug-tools/integration_tool_w/wr/temp/logs.txt 1978-01-17 11:40:09.058893
/usr/local/tools/debug-tools/integration_tool_w/wr/temp/logs.txt
Traceback (most recent call last):
  File "logger.py", line 840, in <module>
    process_logger(logger)
  File "logger.py", line 458, in process_logger
    wd_calistats_analyze()
  File "/usr/local/tools/debug-tools/calling/wm/togtool/calistats.py", line 288, in analyze
    self.tx_audio_calistats_audio_module_analyze()
  File "/usr/local/tools/debug-tools/calling/wm/togtool/audio_log.py", line 219, in analyze
    self.audio_tx_plot()
  File "/usr/local/tools/debug-tools/calling/wm/togtool/audio_log.py", line 258, in audio_tx_plot
    self.get_title_with_viewid('audio_tx_metrics_and_degrading_quality'), annotation_list(annotation_list)
  File "/usr/local/tools/debug-tools/calling/wm/togtool/ottilib.py", line 502, in show_metrics_events
    fig_axes = plt.subplots(numrows, numcols, sharex=True)
  File "/usr/local/lib/python2.7/site-packages/matplotlib-1.3.1-py2.7-Linux-x86_64.egg/matplotlib/figure.py", line 1846, in subplots
    fig = Figure(**fig_kw)
  File "/usr/local/lib/python2.7/site-packages/matplotlib-1.3.1-py2.7-Linux-x86_64.egg/matplotlib/backends/backend_tkagg.py", line 423, in figure
    *kwargs)
  File "/usr/local/lib/python2.7/site-packages/matplotlib-1.3.1-py2.7-Linux-x86_64.egg/matplotlib/backends/backend_tkagg.py", line
  79, in new_figure_manager
    return new_figure_manager_given_figure()
  File "/usr/local/lib/python2.7/site-packages/matplotlib-1.3.1-py2.7-Linux-x86_64.egg/matplotlib/backends/backend_tkagg.py", line
  87, in new_figure_manager_given_figure
    window = Tk.Tk()
  File "/usr/local/lib/python2.7/lib-tk/TKinter.py", line 1245, in __init__
    self.tk = _tkinter.createTkScreenName, baseName, classObjName, interactive, wantobjects, useTk, sync, use)
_tkinter.TclError: no display name and no DISPLAY environment variable
```



Admin Portal – Reports

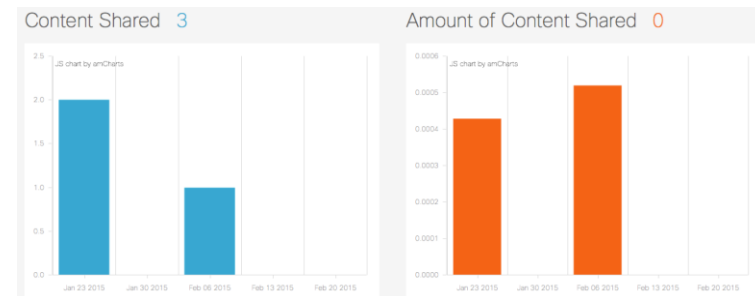
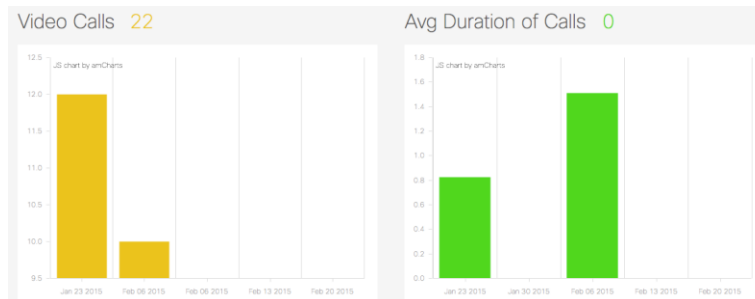
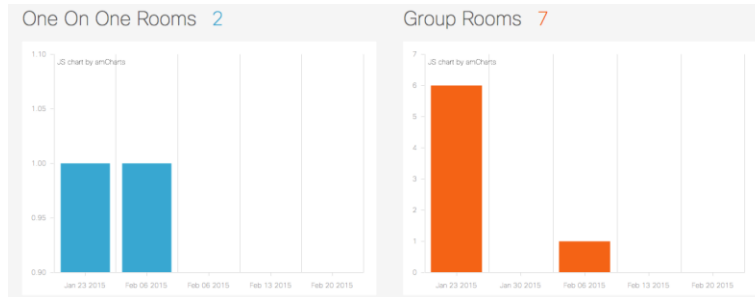
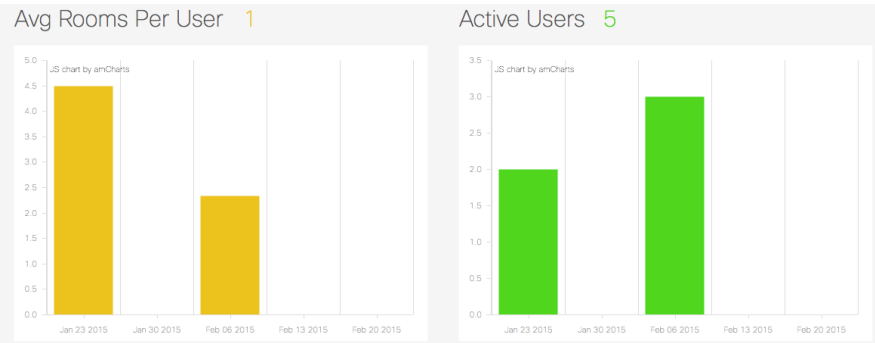
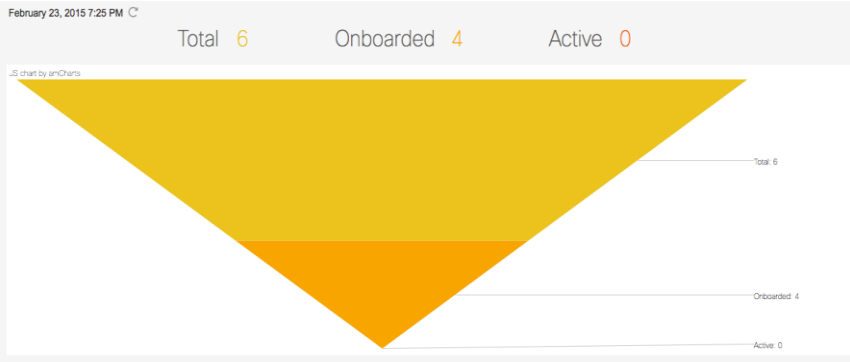



Hybrid Cloud Collaboration Today

CMR Hybrid Cloud Architecture

Recommended Deployment

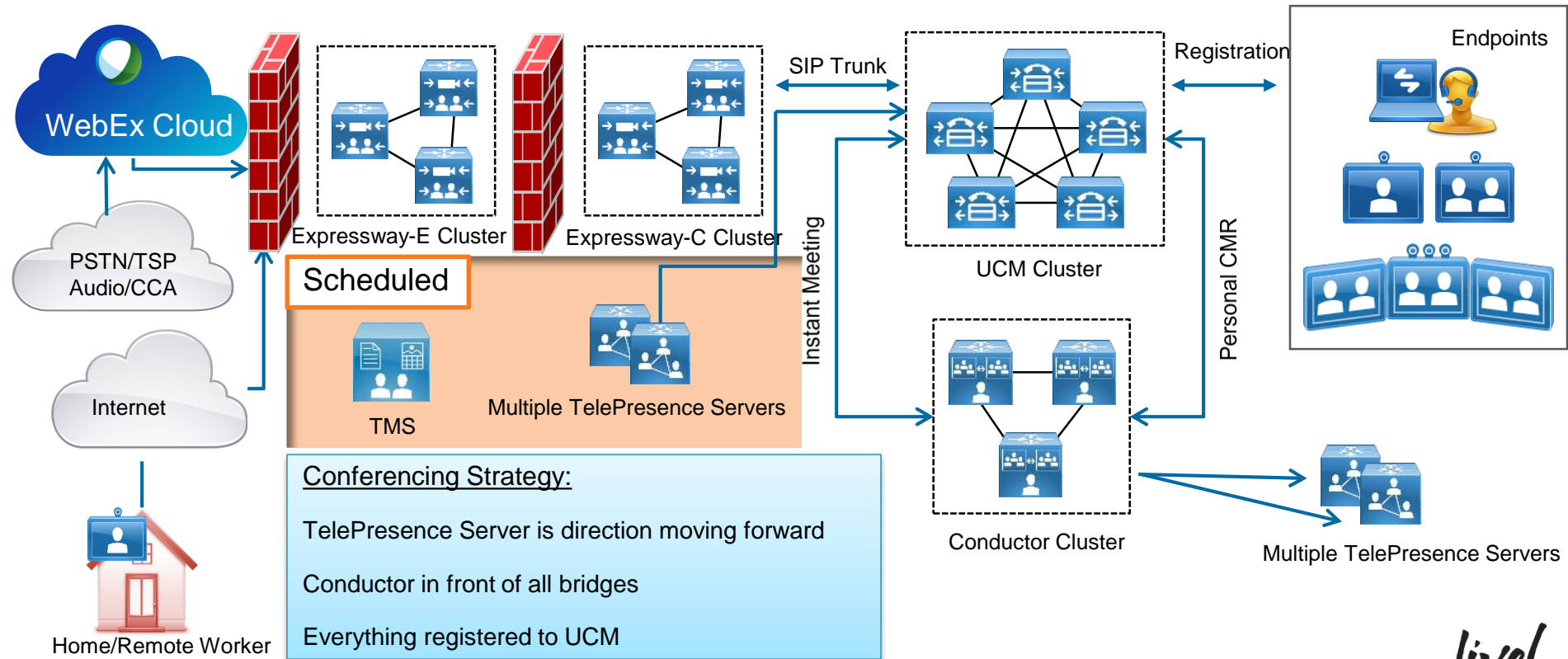



Future...The Fusion of On-Prem and Cloud

Fusion ... Integrating Premise and Cloud

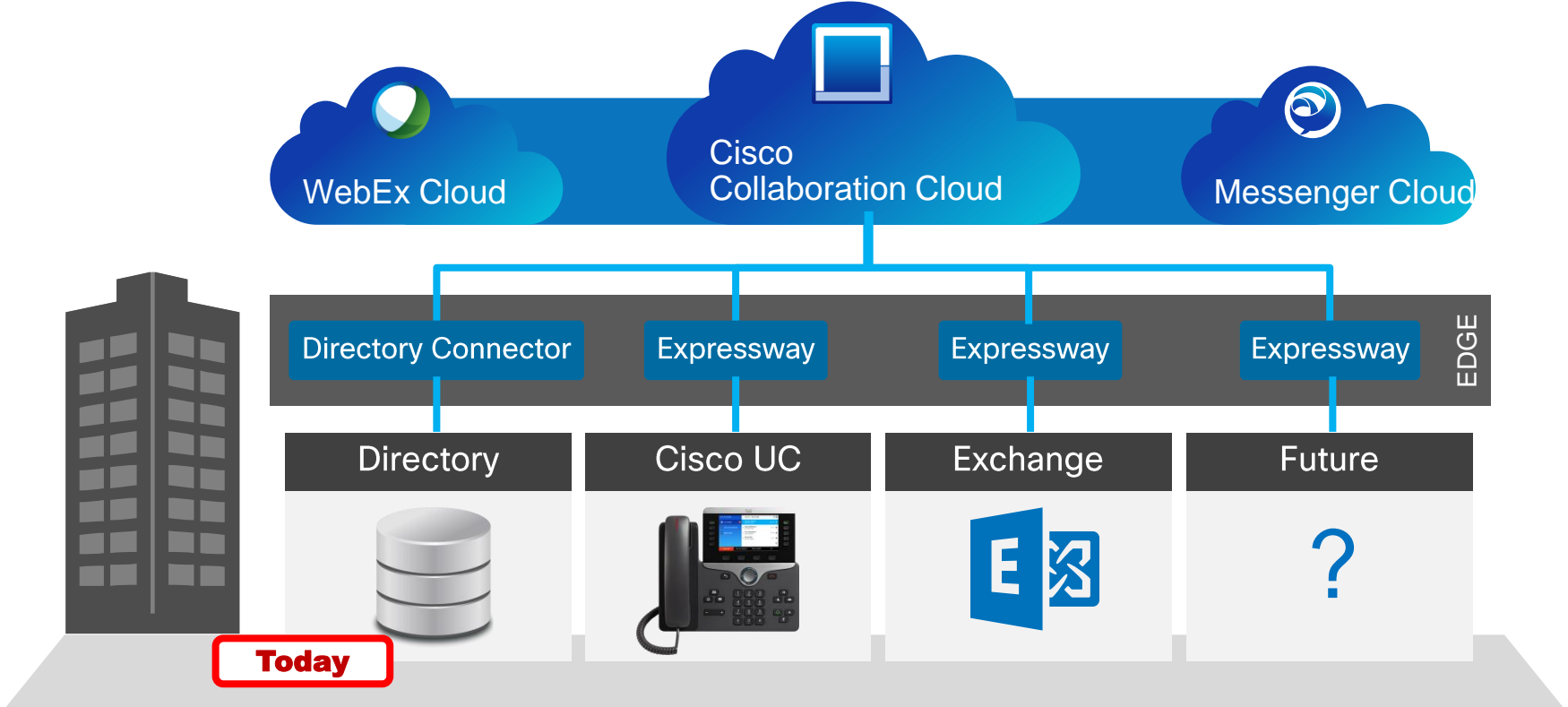

Fusing Directory

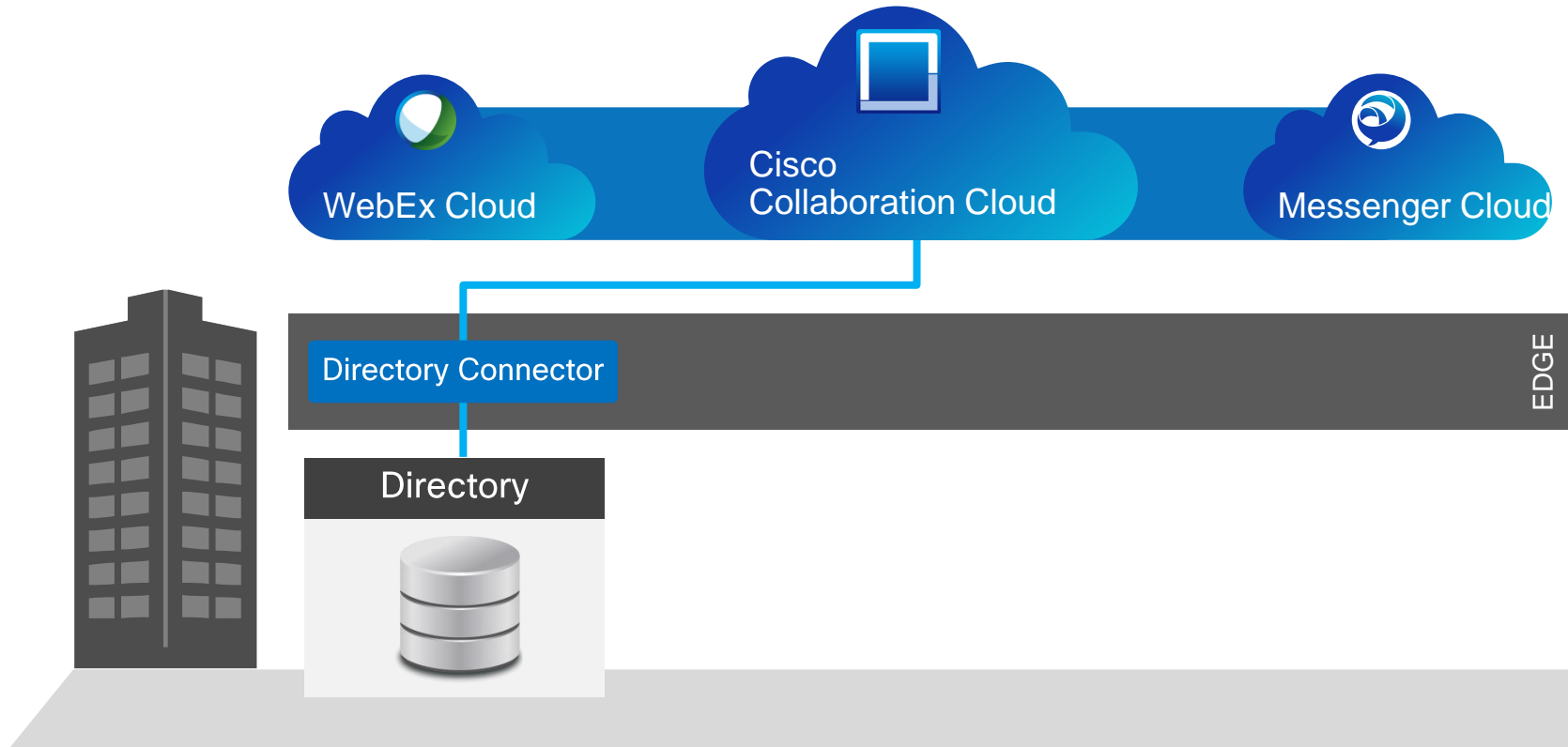

Mapping Users in AD via Directory Connector

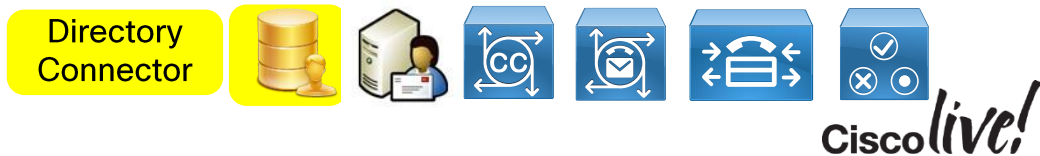
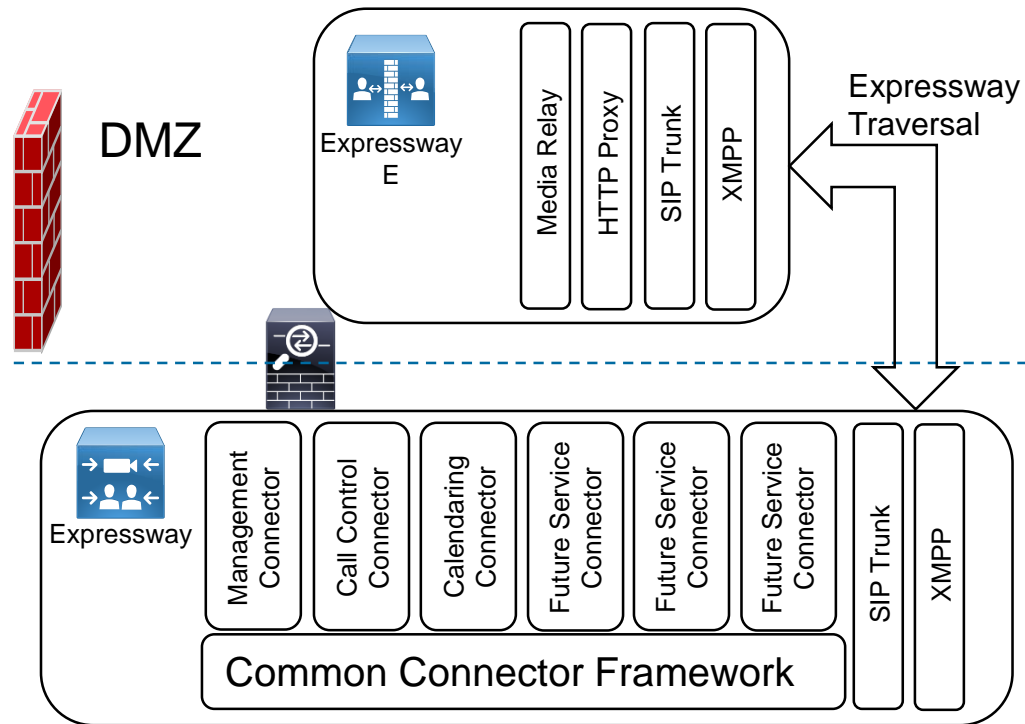
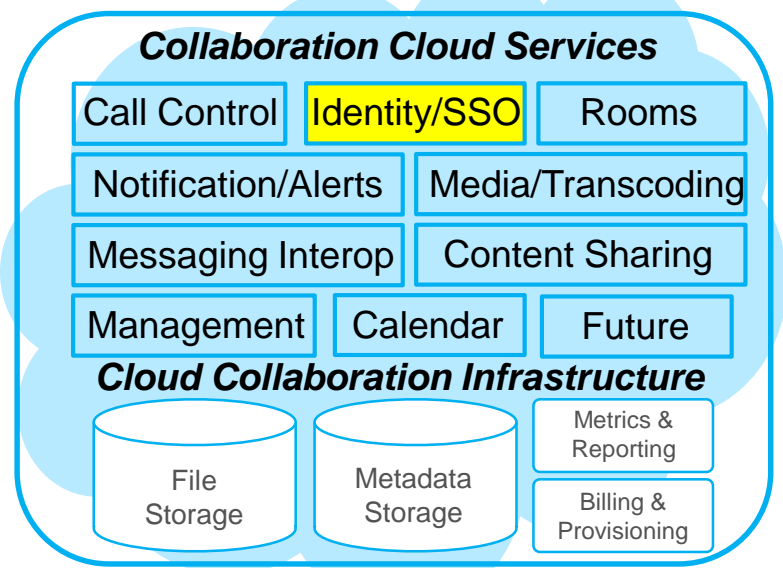

Provisioning via Directory Connector

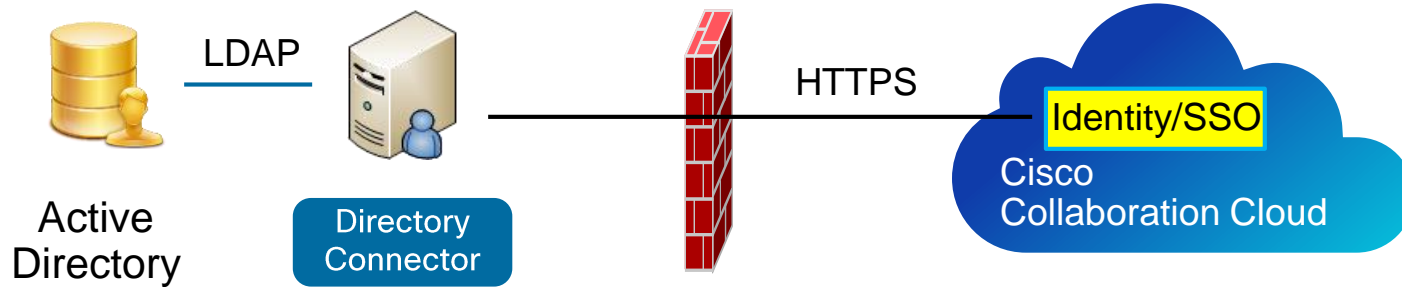

- Infrastructure for premise directory synchronisation to Common Identity cloud services (CIS)
- Customer installs Directory Connector in its network on a Windows Domain server
- Customer configures Directory Connector to specify its AD synchronisation information
- Directory connector integrates with AD to retrieve user information and syncs with CIS

Cisco Cloud (DirSync) Connector

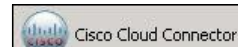

**Subject to
Change**

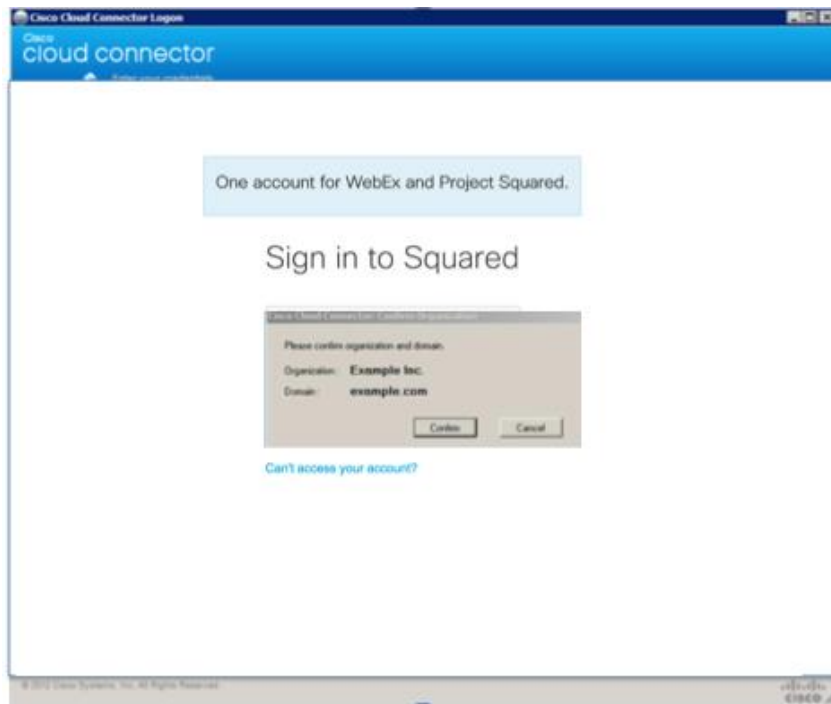

Admin Portal DirSync User Configuration

**Subject to
Change**

Plan Review
Overview of your collaboration plan

Enterprise Settings
Set up global configurations

Add Users
Simple | Advanced

Calls
22

JS chart by amCharts
12.5
12.0
11.5
11.0
10.5

Need help?

Add Users

Simple

All you need are users' email addresses

Advanced

Synchronize users from Active Directory

Next

Admin Portal DirSync AD Domain

**Subject to
Change**

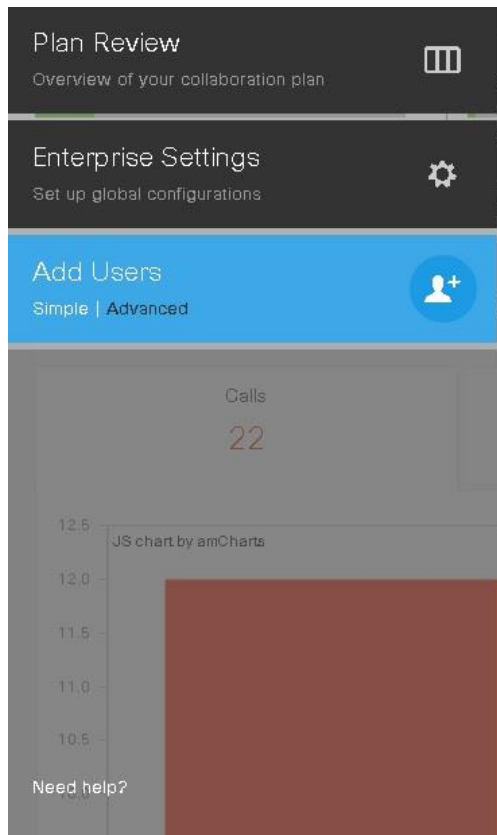

The screenshot shows a vertical navigation menu with four main items:

- Plan Review**: Overview of your collaboration plan. Includes a list icon.
- Enterprise Settings**: Set up global configurations. Includes a gear icon.
- Add Users**: Simple | **Advanced**. Includes a person icon with a plus sign.
- Calls**: 22. Includes a bar chart with the text "JS chart by amCharts".

At the bottom of the menu is a "Need help?" link.

Add Users | Advanced

Domain Entry

Enter the AD domain to sync with:

Domain

Identify the Active Directory domain you will be syncing.

Back

Next

Admin Portal Connector Installation

**Subject to
Change**

The screenshot shows the Admin Portal interface. The top navigation bar includes 'Plan Review' (Overview of your collaboration plan), 'Enterprise Settings' (Set up global configurations), and 'Add Users' (Simple | Advanced). The 'Add Users' section is highlighted in blue. Below the navigation bar, there is a 'Calls' section showing '22' and a 'JS chart by amCharts' section showing a bar chart with a value of 12.0. A 'Need help?' link is visible at the bottom left.

Add Users | Advanced

Install Cloud Connector

Follow these steps in order to install the Cloud Connector:

1. Download and Install the Cisco Cloud Connector in your enterprise.
2. Configure the Active Directory synchronization agreement.
3. Test the synchronization agreement.

Press the Next button when you're ready to verify that identity information is being synchronized.

Back

Next

Hybrid Cloud

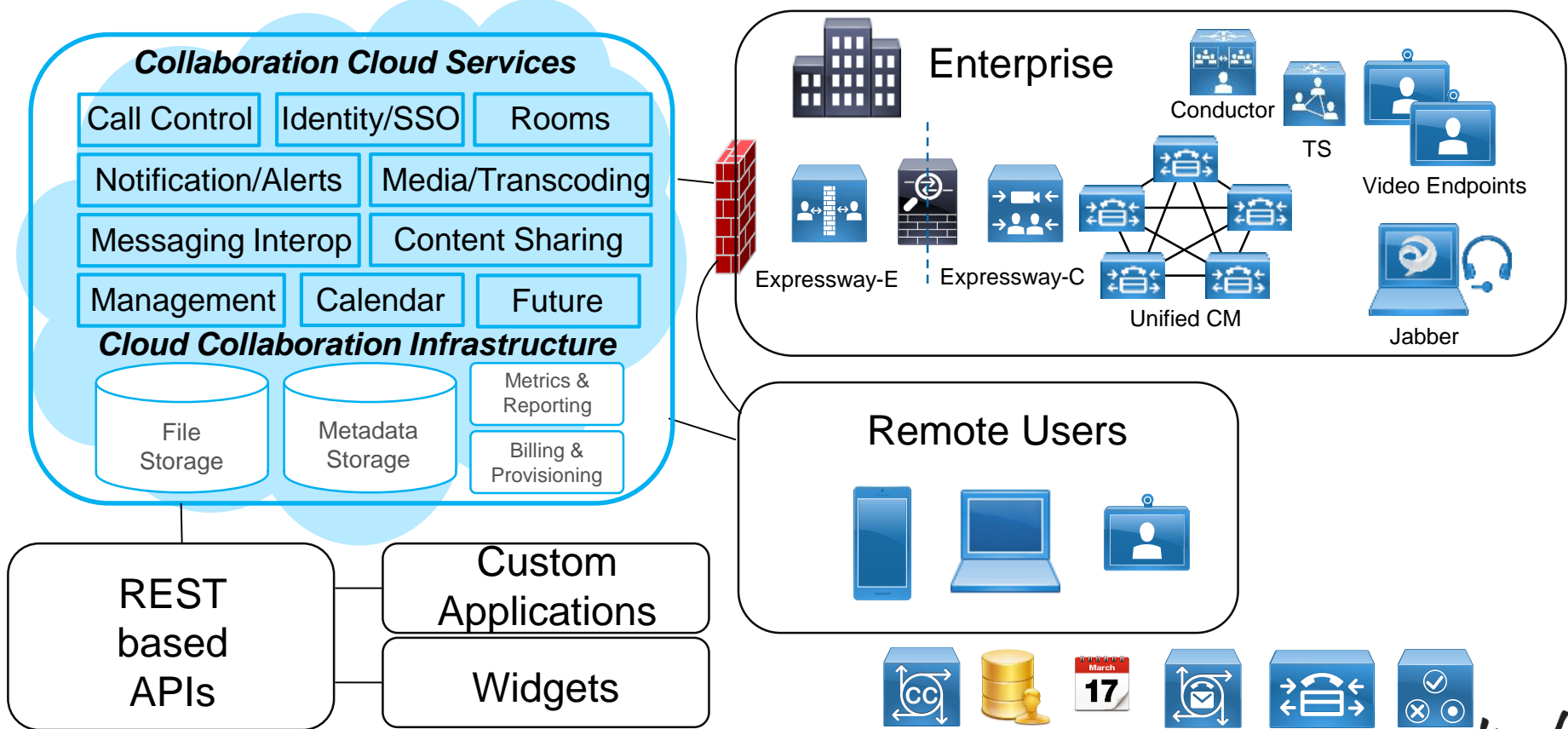

The Edge – Expressway

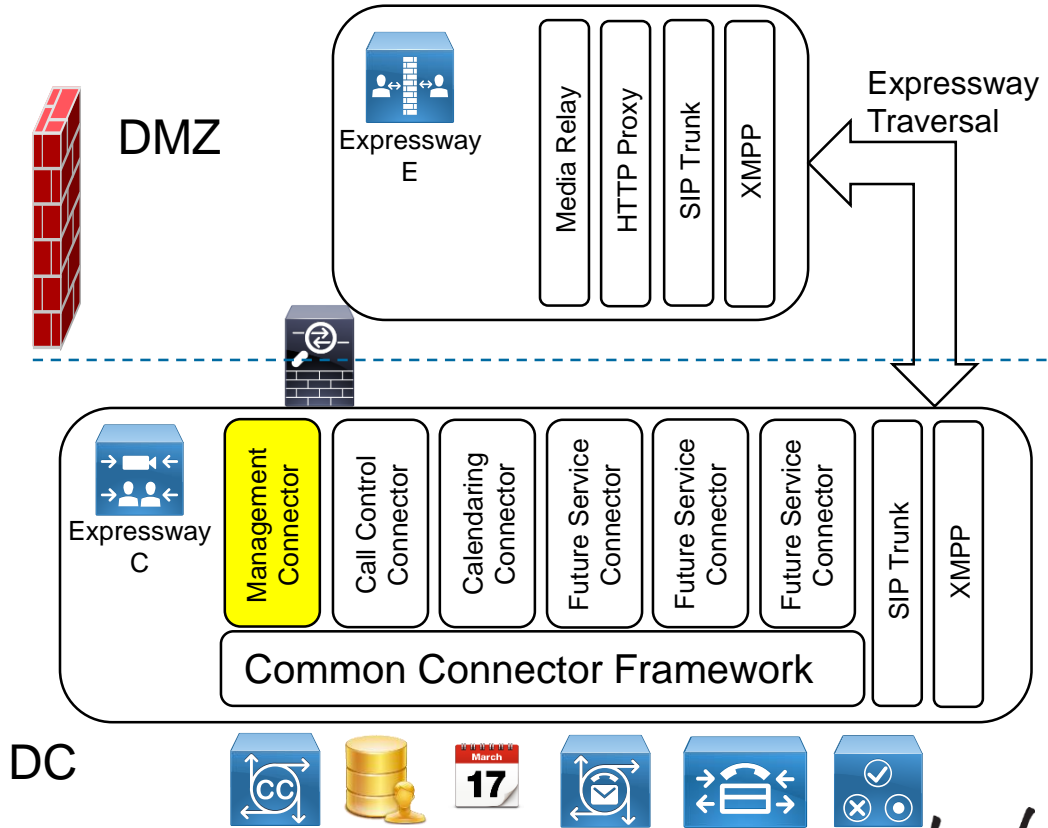
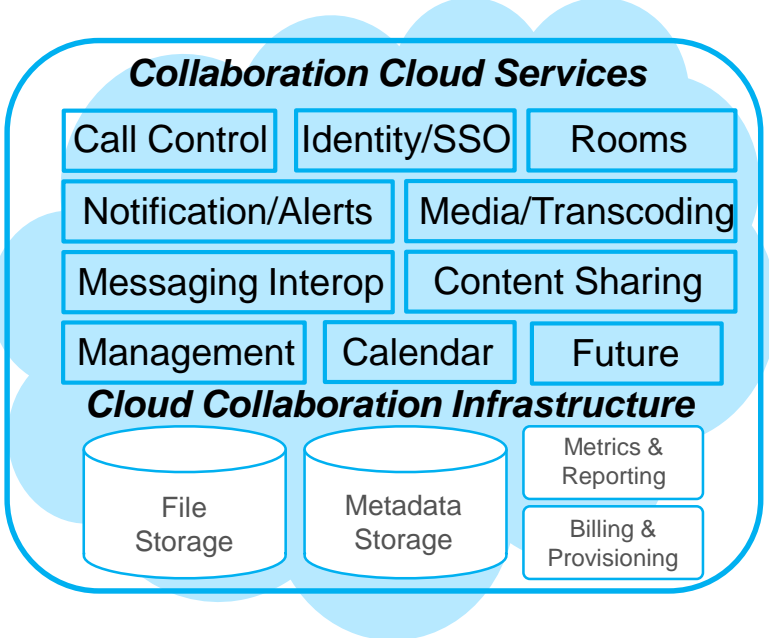

Fusing Unified Communications

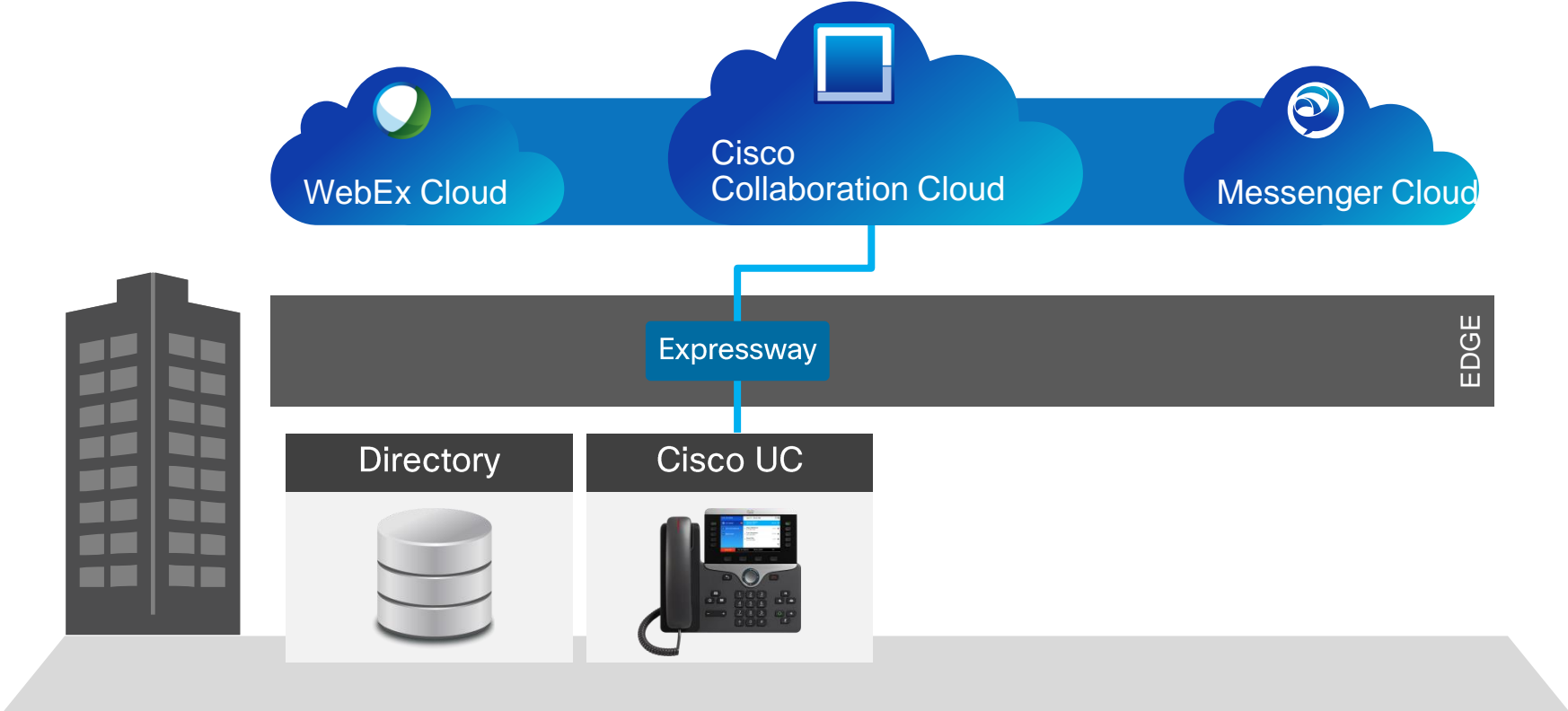

Fusing Cloud and Premise Calling

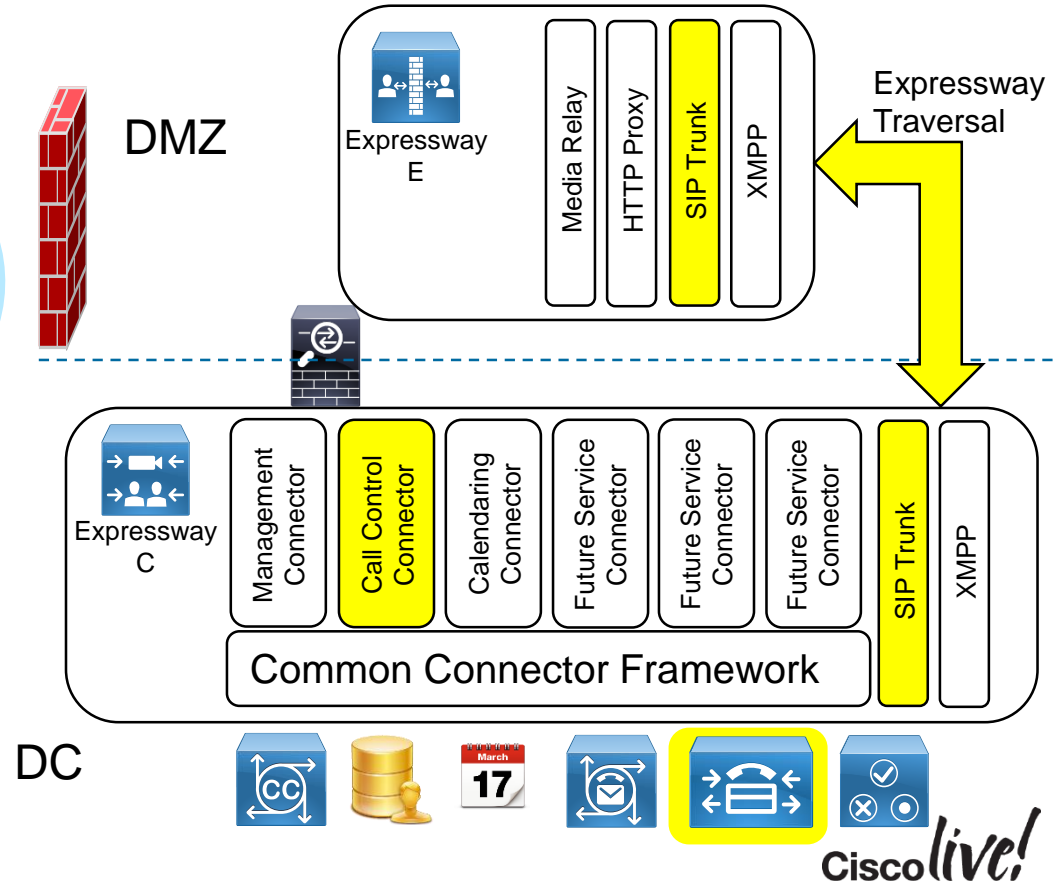
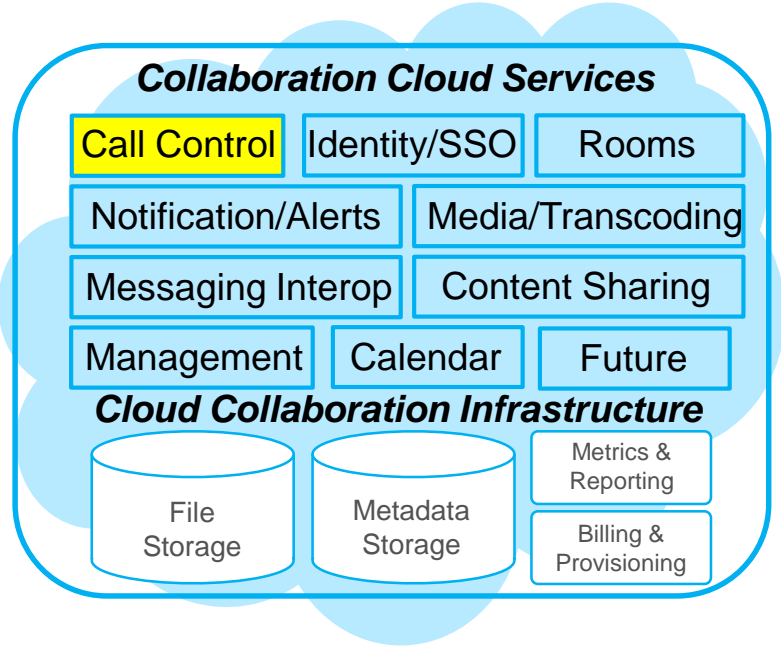

Fusing Exchange Calendar

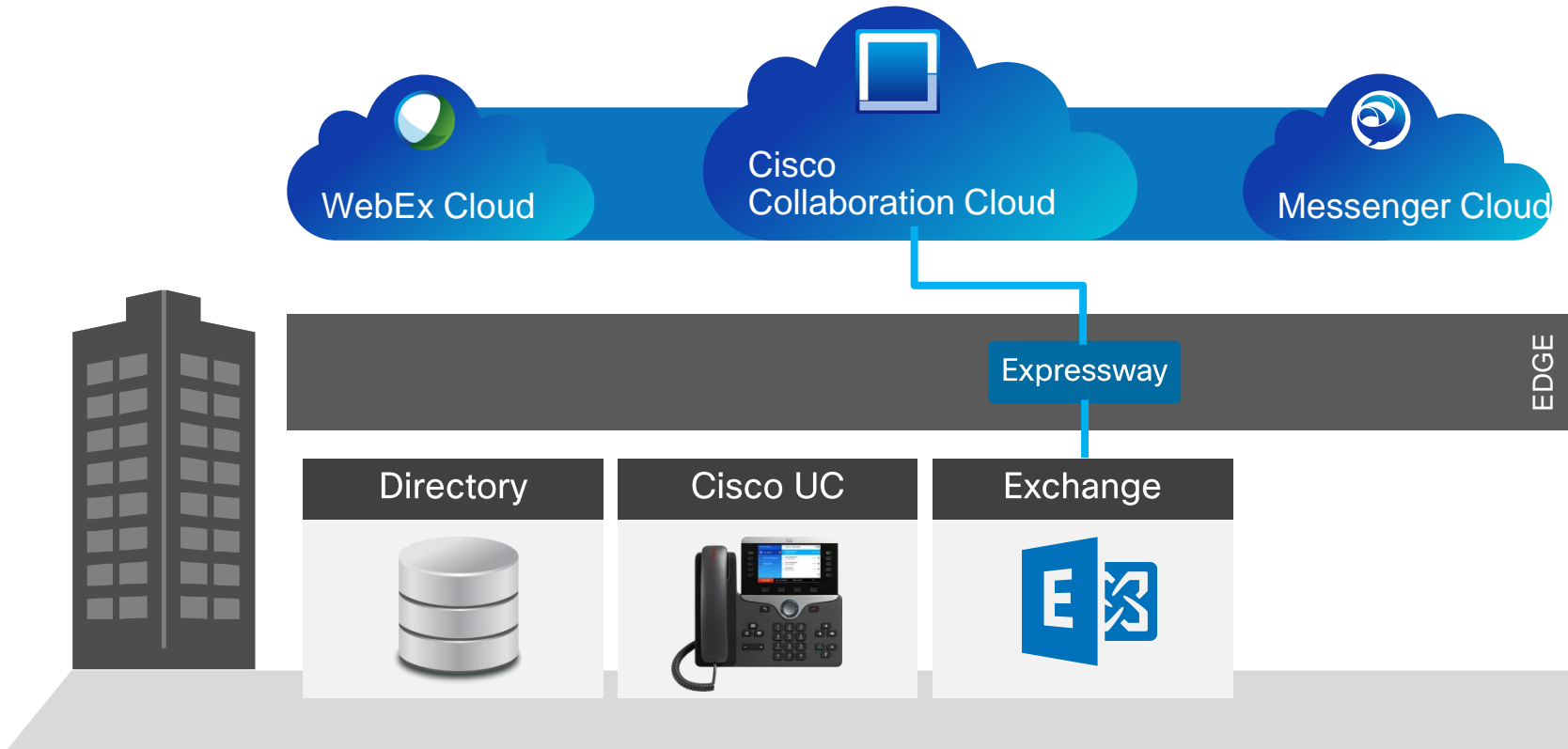

Integrating Exchange Calendar

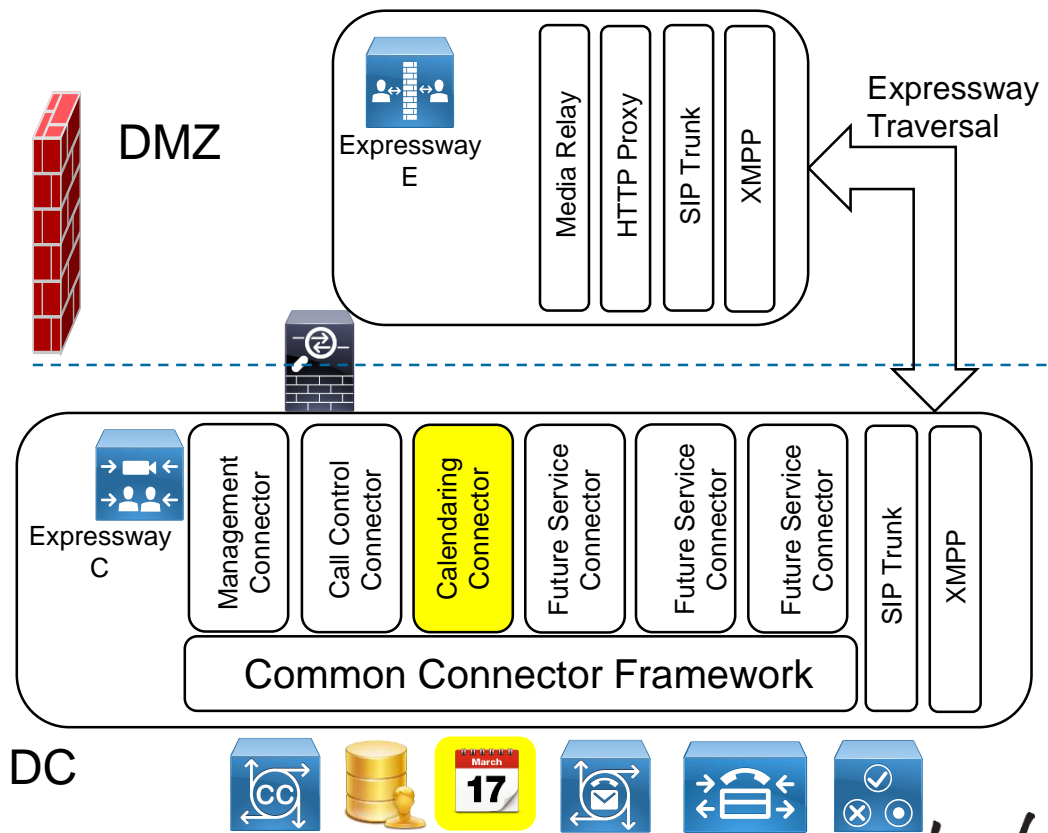
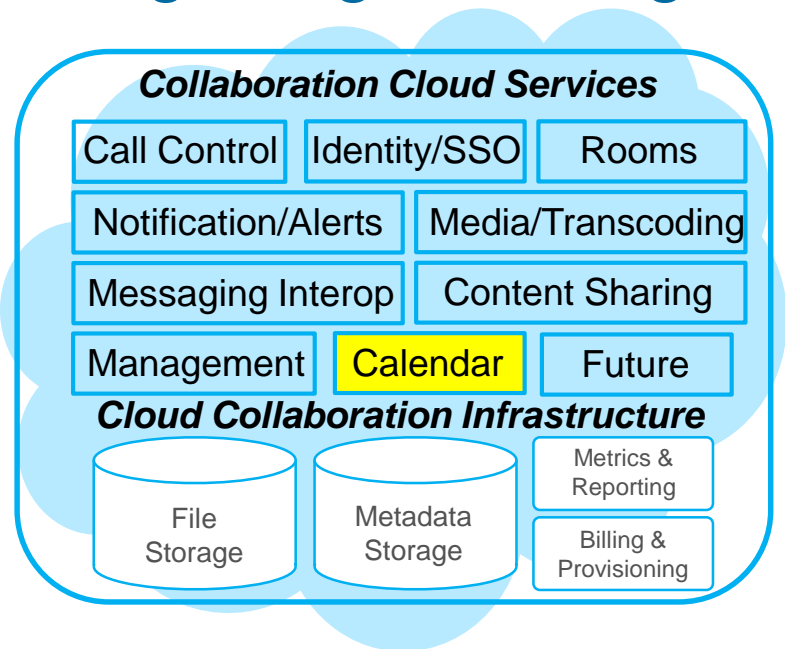

Future Fusing of Premise and Cloud

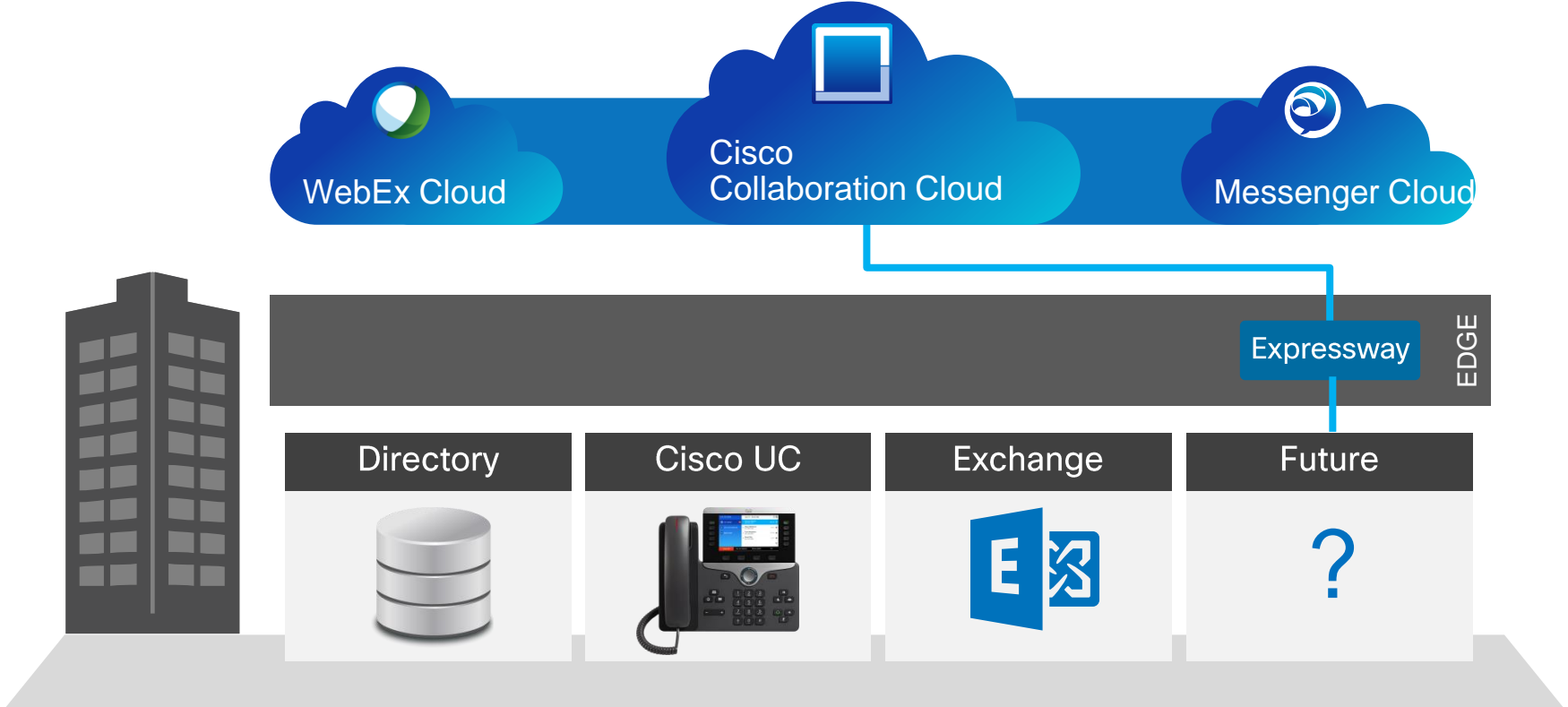

Future of Cisco Collaboration Cloud Platform

***Future**

Stack Fusion : Openstack / Intercloud Platform

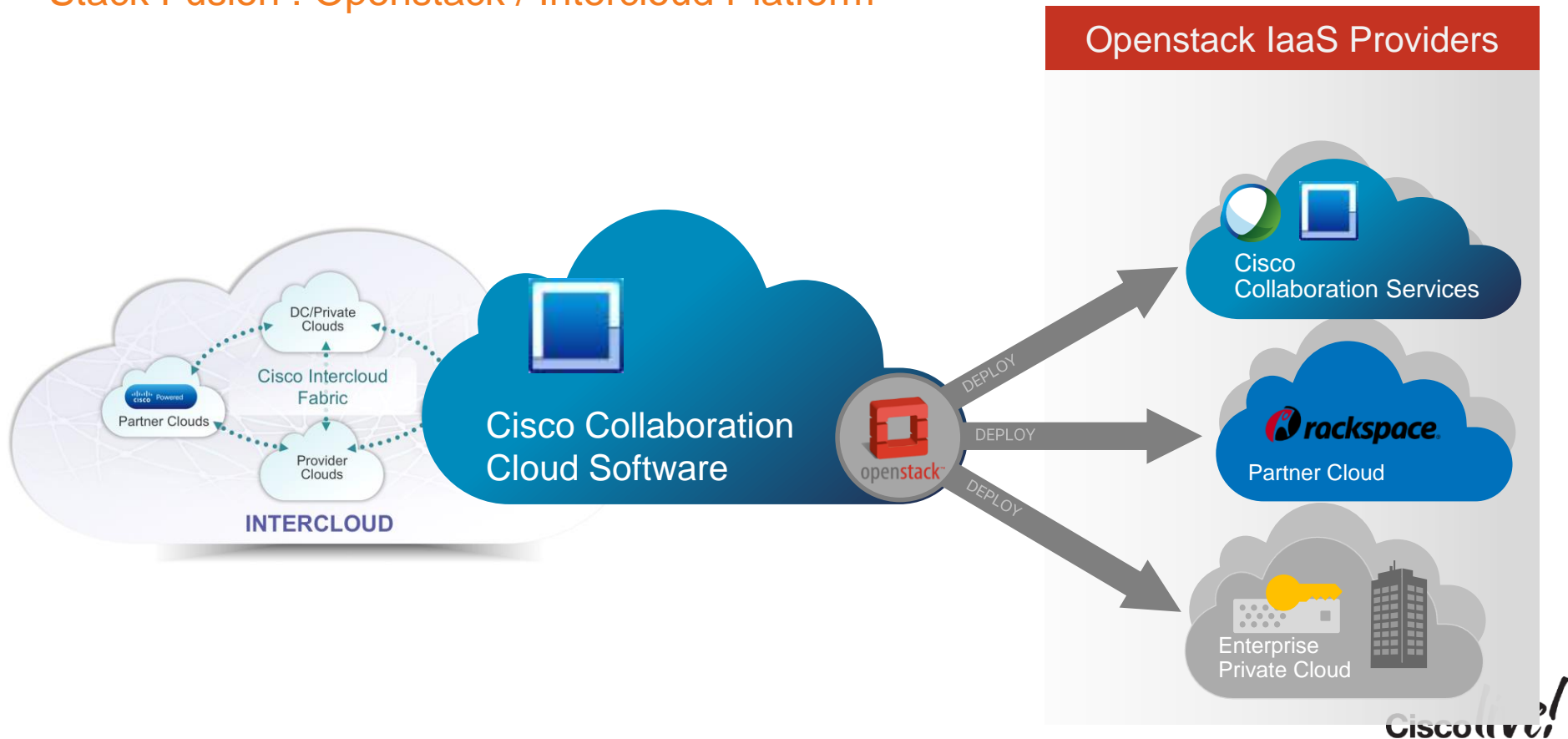

Cisco Collaboration Architecture ... Fused

Best of Cloud and On-Prem

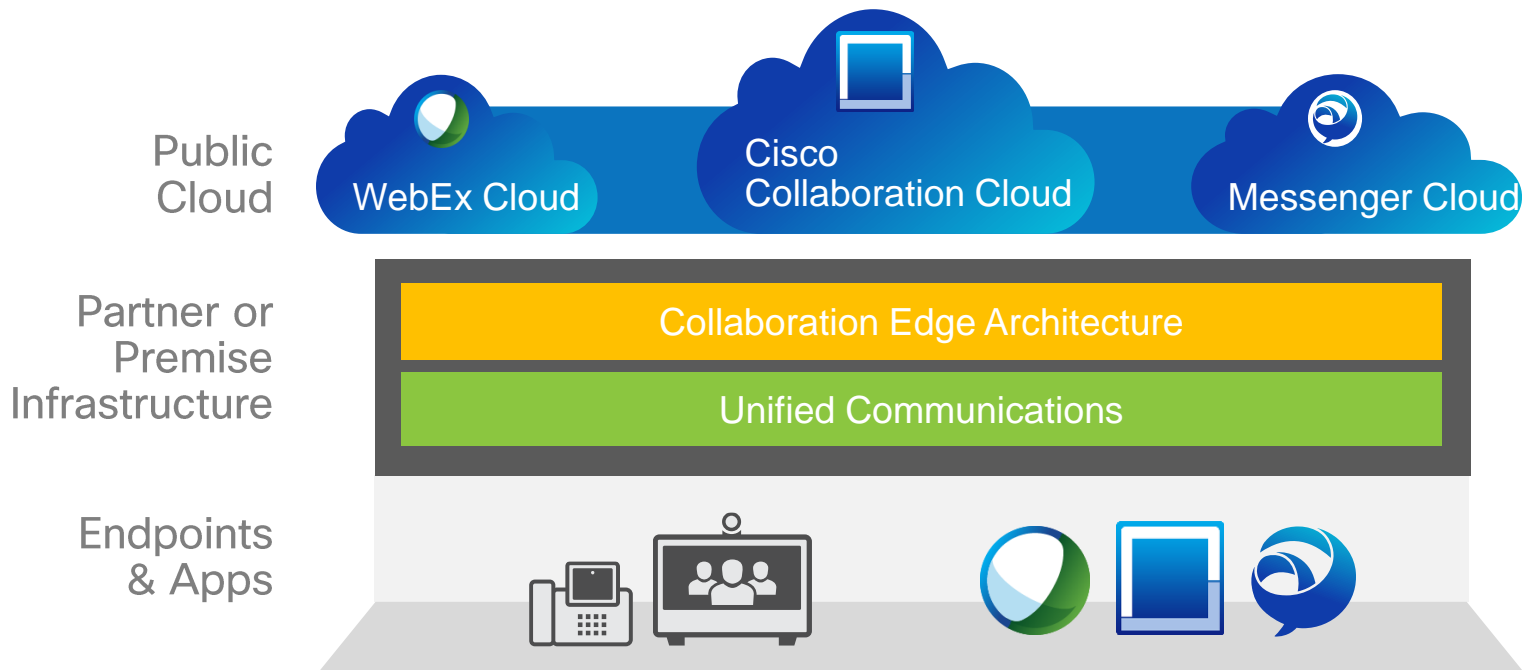



Q & A

Cisco *live!*

Complete Your Online Session Evaluation

Give us your feedback and receive a Cisco Live 2015 T-Shirt!

Complete your Overall Event Survey and 5 Session Evaluations.

- Directly from your mobile device on the Cisco Live Mobile App
- By visiting the Cisco Live Mobile Site
<http://showcase.genie-connect.com/clmelbourne2015>
- Visit any Cisco Live Internet Station located throughout the venue

T-Shirts can be collected in the World of Solutions on Friday 20 March 12:00pm - 2:00pm



Learn online with Cisco Live!

Visit us online after the conference for full access to session videos and presentations. www.CiscoLiveAPAC.com

Cisco *live!*



Thank you.

Cisco *live!*



CISCO