

Catalyst 9300 Stackwise System Architecture

Overview

The network access model in the enterprise campus has evolved significantly from basic user connectivity to an intelligent, powerful, and high-speed building block. Security, cloud, mobility, and the Internet of Things (IoT) in enterprise networks have been driving the network toward major innovations. Cisco® Catalyst® 9000 software and hardware have been designed to address these current and future demands.

Wireless technology is the industry's new megatrend, and it presents a multidimensional challenge to enterprise IT organizations. This swiftly growing technology, with exponentially increasing numbers of mobile devices with high-performance demands, is rapidly changing the landscape of network infrastructure and its reliability. IT requires a reassessment of traditional network models and assembly of network designs that can respond with a broad set of evolutionary architectures. Stacking provides an opportunity to use a pay-as-you-grow model to meet these demands.

As the wired and wireless Gigabit evolution begins at the access layer, user and application demands will increase to high-speed, low-latency data switching for optimal performance. Cisco has built a system architecture to support such innovations. The Cisco Catalyst 9000 family of switches were developed to meet these demands. The Cisco Catalyst 9000 family is completely revamped with modular Cisco IOS® Software (Cisco IOS XE) and a flexible Application-Specific Integrated Circuit (ASIC), called the Cisco Unified Access® Data Plane (UADP), with an x86 CPU to handle the future needs of the network. Cisco Catalyst 9300 Series Switches with Cisco StackWise®-480 offer platform, software, and network resiliency at the access layer. The 9300 Series is the industry's highest-density stacking bandwidth solution with flexible uplink architecture. This white paper talks in detail about the benefits and architecture of StackWise-480.

Contents

Overview

Introduction to StackWise-480

Stacking components

- Stack ports
- Stack connectors

Stacking architecture

- Ring architecture
- Stack discovery
- Active election
- Stackwise-480 architecture
- Distributed forwarding architecture
- SSO/NSF architecture
- Implementing StackWise-480
- NSF/SSO

Stack operations

- Switch addition
- Switch deletion
- Stack split
- Stack merge
- Auto-upgrade

Licensing

- Licensing with Release 16.9 (Smart Licensing)
- Licensing prior to Release 16.9

Stack design

- Simplified multilayer network design
- Scalable StackWise-480 cross-stack EtherChannel design
- Optimal StackWise-480 cross-stack forwarding EtherChannel design
- Reliable StackWise-480 cross-stack forwarding Ether Channel design

Summary 23

Introduction to StackWise-480

The StackWise-480 architecture allows stacking of up to eight switches in a ring topology to achieve 480G of stack bandwidth. The stacking architecture expands form factor, switching capacity, port density, and redundancy as well as providing a single control plane. This architecture provides resiliency, scalability, and central management. The latest Cisco Catalyst 9300 Series Switches support StackWise-480. This technology is flexible, modular, and evolutionary, and it delivers Cisco IOS XE feature capabilities with hardware acceleration to every port in the stack.

Cisco Catalyst 9300 Series Switches come in data, Power over Ethernet (PoE), Cisco Universal Power over Ethernet (Cisco UPOE®), and Multigigabit versions. Each version has 24-port and 48-port variants. The hardware design of each model is cost-effective to support different network capacity load and switching performance.

Up to a maximum of eight switches can be stacked together physically in a ring topology to form a single, unified, virtual stack system. A Cisco Catalyst 9300 Series Switch, when deployed in StackWise-480 mode, has been designed to deliver deterministic and nonblocking switching performance to a maximum port density of 448 ports with a distributed data plane, single control plane, and management plane. The switching performance delivers hardware-accelerated, integrated borderless network services such as PoE, PoE+, Cisco UPOE, Quality of Service (QoS), Access Control Lists (ACLs), Flexible NetFlow, Cisco Encrypted Traffic Analytics (ETA), streaming telemetry, and many more services on every port.

Depending on the requirement of each switch in the stack, a Cisco Catalyst 9300 Series Switch provides the flexibility for mixed-mode support between different models in a single stack ring. You can mix switches with different model variants (PoE, Cisco UPOE, data, Multigigabit) and different network modules in the stack.

Figure 1 shows the StackWise-480 technology when four switches are part of the stack. Figure 2 shows simplified physical and logical views of a stack.

Figure 1. Cisco Catalyst 9300 Series StackWise-480 technology

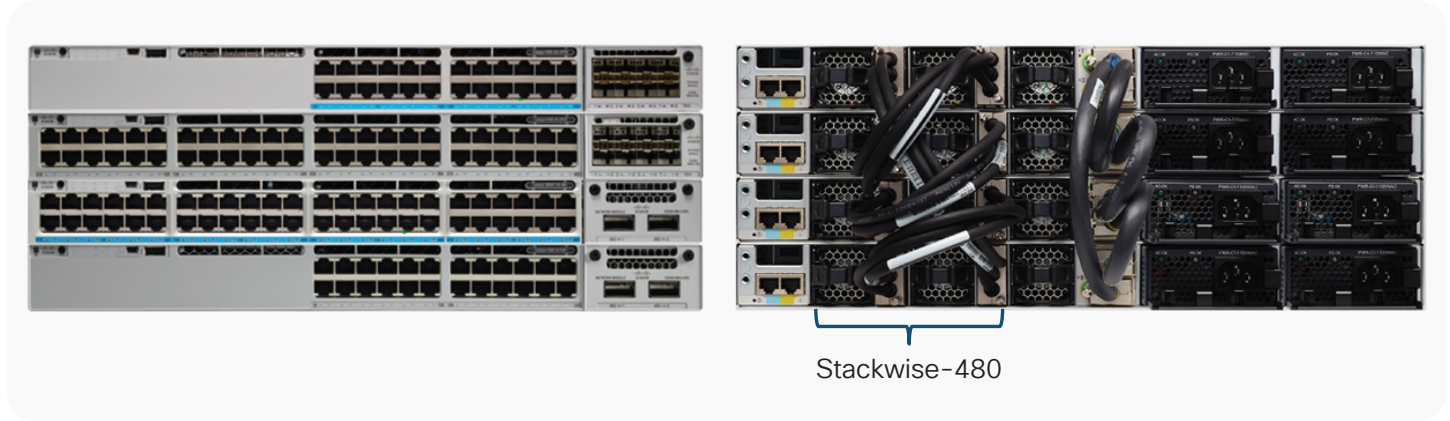
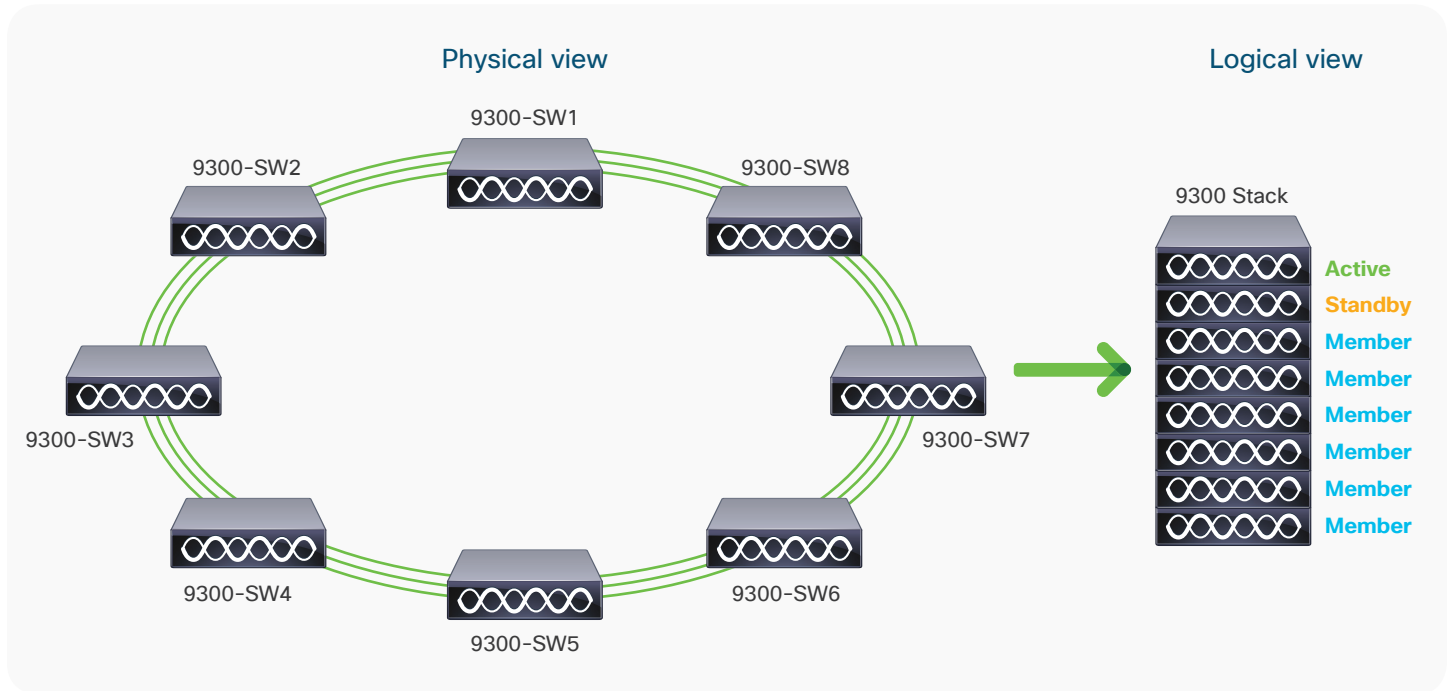

Figure 2. Simplified Cisco Catalyst 9300 Series physical and logical views



Stacking components

Stacking cables are mandatory for stacking architecture. Stacking cables that support Cisco Catalyst 3850 Series Switches can be used for the 9300 Series switches, making them backward compatible. Depending on the physical setup of the infrastructure, different lengths of stacking cable may be needed. Each Cisco Catalyst switch supports a maximum of two stack cables for data stacking. Table 1 lists the stacking cables available.

Table 1. Different orderable stack cables

Product ID	Description
STACK-T1-50CM	50CM Type 3 Stacking Cable
STACK-T1-1M	1M Type 3 Stacking Cable
STACK-T1-3M	3M Type 3 Stacking Cable

Stack ports

Each Cisco Catalyst switch comes with two stack ports located on the back panel of the switch to support the StackWise-480 architecture. Figure 3 shows the stack port location on the 9300 Series switches.

Figure 3. Stack cable and stack cable slot

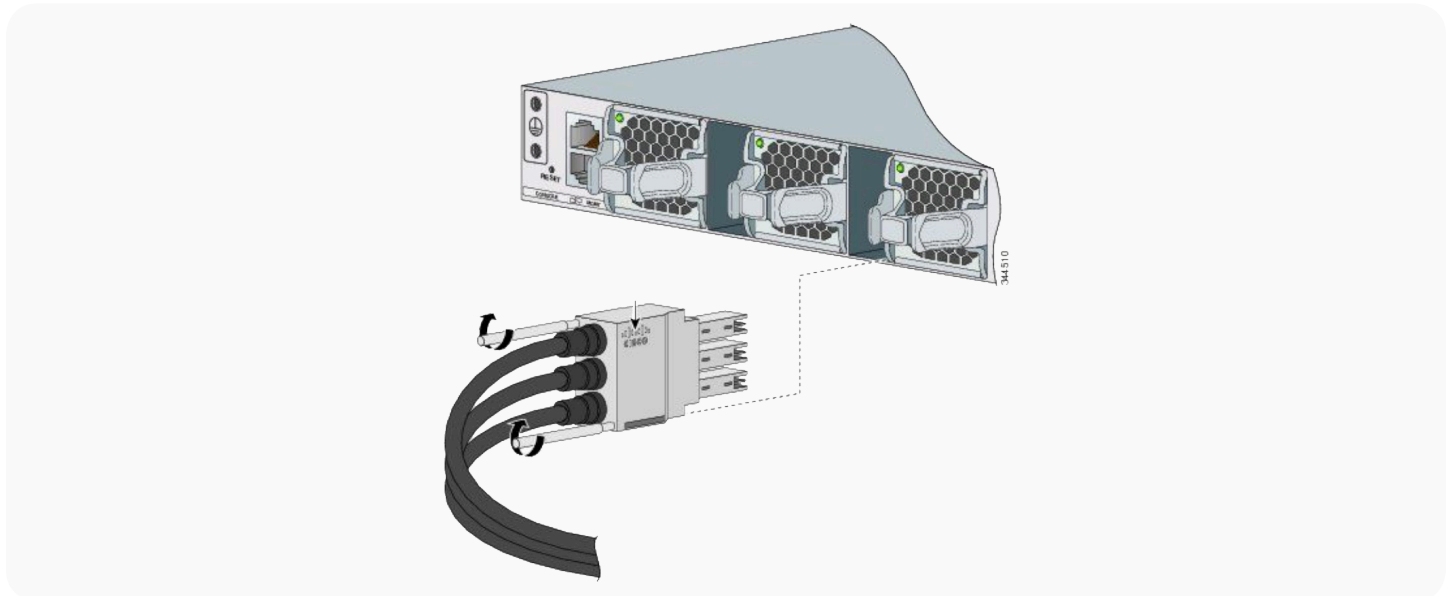

Stack connectors

Figure 4 shows the stack connector. All stack ports are identical on all models of the Cisco Catalyst 9300 Series Switches. Any side of the stack cable can connect to any stack port. Make sure the screws are completely tightened and the connection is secure.

Figure 4. Stack connector



Stacking architecture

Ring architecture

When the stack is operating in a full ring, it can deliver high-speed performance throughput of 480 Gbps by each stack-member switch. This multifold performance improvement is possible by combining the new internal UADP ASIC and dual stack ports.

The high-speed backplane of the Cisco Catalyst 9300 Series stack-ring fabric is constructed by daisy-chaining the stack-member switches with Cisco proprietary cables that connect rear-side stack ports. The Cisco stack fabric consists of six unidirectional data transmission rings.

Figure 5 provides a graphical illustration of the 9300 Series StackWise-480 internal forwarding architecture.

Figure 5. Cisco Catalyst 9300 StackWise-480 internal forwarding architecture

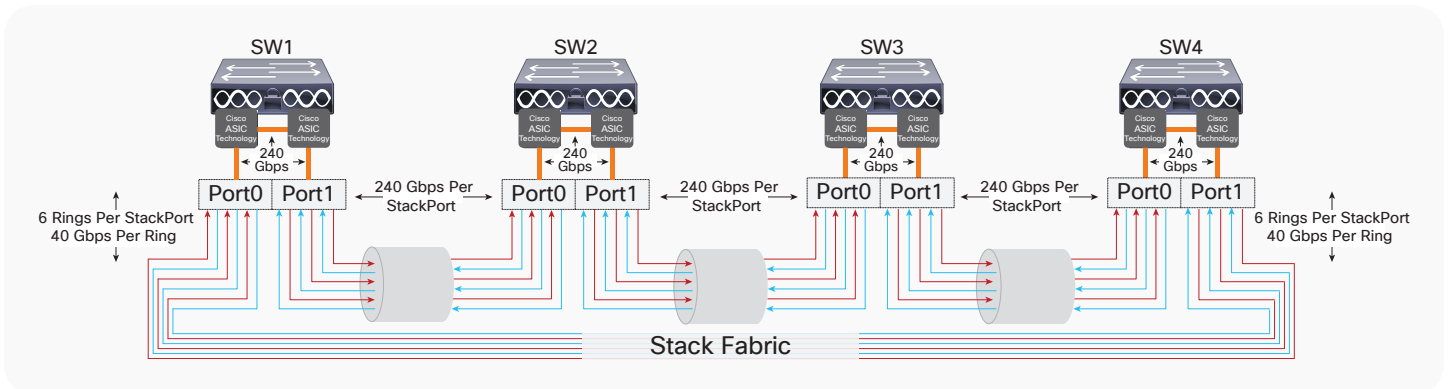

The aggregated throughput that a stack of switches supports is a combination of two major factors:

Total transmission rings: Each stack connector bundles multiple individual cables that carry data across the stack ring. This cabling structure creates six internal stack rings. This hardware design significantly improves the data transmission performance of each stack port of a Cisco Catalyst 9300 Series Switch.

Maximum throughput per ring: Each stack ring can transmit data up to 40 Gbps. These six internal stack rings will enable an aggregated throughput of 240G per switch (up to 480G of unicast with Spatial Reuse Protocol [SRP]).

Table 2 describes the major details of the stacking architecture.

Table 2. Cisco StackWise architecture details

	Catalyst 9300 Stackwise-480
Total number of rings	6
Throughput per ring	40 Gbps
Throughput per stack (full ring)	240 Gbps
Throughput per stack (full ring)with SRP	480 Gbps

Stack discovery

Once all switches are powered on and the stack interfaces are up, the Stack Discovery Protocol (SDP) discovers the stack topology using broadcasts. Neighbor information is shared with all other switches in the stack. In a full ring, discovery exits after all the members are found. In a half ring, the system waits for two minutes. Once all switches are discovered, switch numbers are determined. After switch number conflicts are resolved, the information is stored in a flash variable block for future use. ACTIVE election begins after discovery exits.

The following command can be used to check the status of the stack cable and to identify the neighbor device of the stack cable.

```
9300-STACK#sh switch stack-ports summary
```

Sw#/Port#	Port	Status	Neighbor	Cable Length	Link OK	Link Active	Sync OK	#Changes to LinkOK	In Loopback
1/1	OK	2	50cm	Yes	Yes	Yes	1	No	
1/2	OK	4	100cm	Yes	Yes	Yes	1	No	
2/1	OK	3	50cm	Yes	Yes	Yes	1	No	
2/2	OK	1	50cm	Yes	Yes	Yes	1	No	
3/1	OK	4	100cm	Yes	Yes	Yes	1	No	
3/2	OK	2	50cm	Yes	Yes	Yes	1	No	
4/1	OK	1	100cm	Yes	Yes	Yes	1	No	
4/2	OK	3	100cm	Yes	Yes	Yes	1	No	

Active election

To determine the single ACTIVE and STANDBY switch role during the complete stack reboot process or during the initial boot-up, all switches are required to go through an election process. All member switches participate in the election of an ACTIVE stack switch if they all boot up within the election window (120 seconds).

The following parameters are taken into account in the order listed below for active switch election:

- Highest priority
- Lowest MAC address

STANDBY is elected by the ACTIVE switch after two minutes to reduce the stress of high-availability sync on the stack.

By default, the priority is 1 for all switches; hence it falls back to the MAC address to determine the ACTIVE switch if a priority is not defined explicitly. The switch with a lower MAC address will take the role of the ACTIVE switch. The remaining switches join the stack as member switches. Once all the switches in the stack are discovered as members, the ACTIVE switch elects the STANDBY switch. Any switch that you add to the stack after the completion of election process is considered a straggler and will not participate in the ACTIVE stack switch election.

For deterministic system role election, it is recommended to adjust the switch priority for all stack switches. The switch with a higher priority becomes the ACTIVE switch. This configuration is a one-step process and is typically

done at the time of the initial switch boot-up. The switch priorities are set in the ROMMON configuration of each individual switch in the stack ring. The switch priority configuration from ROMMON is parsed during the boot cycle instead of reading from the startup configuration stored in NVRAM.

Thus, the switch-priority configuration cannot be verified from startup or the running configuration, since it is programmed into a different configuration component.

The priority of the Cisco Catalyst 9300 Series Switch can be modified from the EXEC mode. A reload is required for the change to take effect. The following commands show how to configure the switch priority and change switch numbers.

Cisco Catalyst 9300 Series

```
9300>enable
9300#switch <number> priority 15
!Set priority 15 to elect switch in ACTIVE role
9300#switch <number> priority 14
!Set priority 14 to elect switch in STANDBY role
9300#switch <number> priority 13
!Set priority 13 to elect switch in next STANDBY role
9300#switch <number> priority 12
!Set priority 12 to elect switch in next STANDBY role
9300>enable
9300#switch <number> renumber <number>
!Statically renumber switch in stack-ring
```

There are two ways to influence a particular switch in the stack to take over the role of an ACTIVE switch:

- Configure the switch with the highest priority [highest priority is 15] to assume the role of the ACTIVE switch.
- If you prefer a particular switch to be the ACTIVE switch in the stack, power on that switch first to take on the role of the ACTIVE switch.

Some conditions apply for switches when deployed in StackWise-480:

- Valid switch numbers are 1 through 8 for Cisco Catalyst 9300 Series Switches. The port numbers of the member switches begin with the switch number, such as Gig1/0/1, Te1/1/1, or Fo1/1/1, depending on whether the ports are Gigabit Ethernet (GE), 10 GE, or 40 GE.
Example: Switch 3 would have G3/0/1, Te3/1/1, Fo3/1/1
- Switch numbers are persistent, meaning that each switch keeps the same switch number after it reboots as a stack member, even if it is no longer part of the stack.
- The stack ACTIVE switch resolves any switch number conflicts and renumbers the switch.
- Switch numbering does not reflect the physical location of the switch. However, the numbering can be changed to match the physical location using the command “**switch current-stack-member-number renumber new-stack-member-number**” from the enable mode.
Example: “switch 1 renumber 2” renames switch 1 to 2 and changes the port numbers from G1/1/1 and Te1/1/1 to G2/1/1 and Te2/1/1. A reload is required for this to take effect.

When you disconnect a stack member, the switch numbers and port numbers of the remaining stack members do not change, and the stack does not reload.

The system roles in the resilient StackWise-480 architecture can be verified by running the commands shown below.

```
9300-STACK#show switch
Switch/Stack Mac Address : 046c.9d1f.3400 - Local Mac Address
Mac persistency wait time: Indefinite
```

Switch#	Role	Mac Address	Priority	H/W Version	Current State
*1	Active	046c.9d1f.3400	15	V01	Ready
2	Standby	046c.9d1f.3b80	14	V01	Ready
3	Member	046c.9d1f.6c00	13	V01	Ready
4	Member	7001.b544.5700	12	V01	Ready

```
9300-STACK#show redundancy
Redundant System Information :
-----
    Available system uptime = 2 days, 20 minutes
Switchovers system experienced = 0
    Standby failures = 0
    Last switchover reason = none

    Hardware Mode = Duplex
Configured Redundancy Mode = sso
Operating Redundancy Mode = sso
    Maintenance Mode = Disabled
    Communications = Up

Current Processor Information :
-----
    Active Location = slot 1
    Current Software state = ACTIVE
    Uptime in current state = 2 days, 20 minutes
    Image Version = Cisco IOS Software [Fuji], Catalyst L3 Switch Software
(CAT9K_IOSXE), Version 16.9.1, RELEASE SOFTWARE (fc2)
Technical Support: http://www.cisco.com/techsupport
Copyright (c) 1986-2018 by Cisco Systems, Inc.
Compiled Tue 17-Jul-18 17:00 by mcpre
    BOOT = flash:packages.conf
    CONFIG_FILE =
    Configuration register = 0x102

Peer Processor Information :
-----
    Standby Location = slot 2
    Current Software state = STANDBY HOT
    Uptime in current state = 2 days, 16 minutes
    Image Version = Cisco IOS Software [Fuji], Catalyst L3 Switch Software
(CAT9K_IOSXE), Version 16.9.1, RELEASE SOFTWARE (fc2)
Technical Support: http://www.cisco.com/techsupport
Copyright (c) 1986-2018 by Cisco Systems, Inc.
Compiled Tue 17-Jul-18 17:00 by mcpre
    BOOT = flash:packages.conf
    CONFIG_FILE =
    Configuration register = 0x102
```

The STANDBY switch, which is in HOT-STANDBY mode, will transition into the ACTIVE role upon detecting failure of the primary ACTIVE switch. A new STANDBY switch will be elected from the available member switches, and it will transition to HOT-STANDBY.

Figure 6 shows the roles and operation of switches in a StackWise-480 architecture.

Figure 6. Roles and operation of StackWise-480

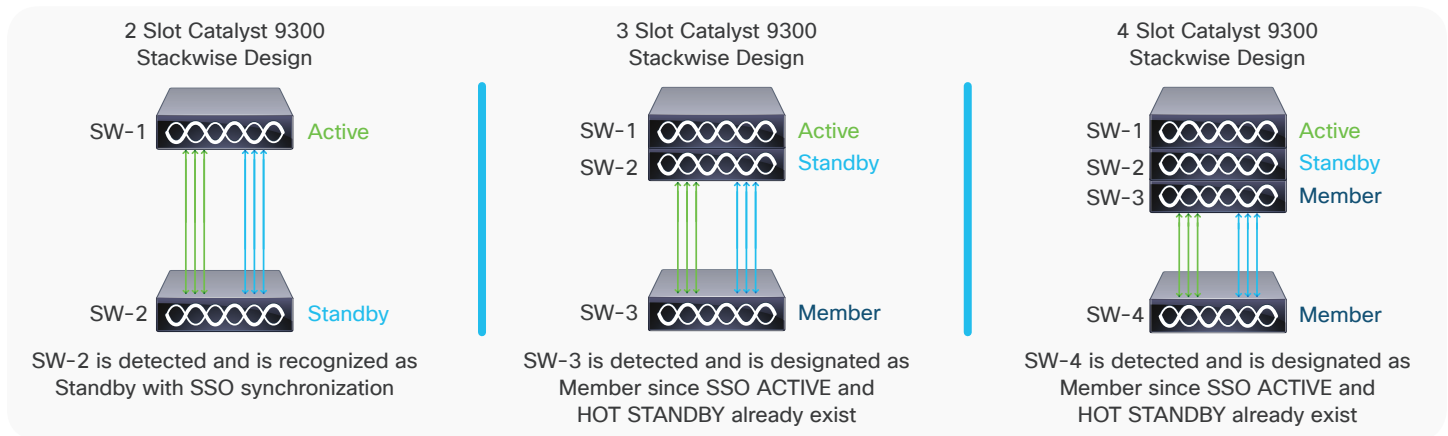

Stackwise-480 architecture

The forwarding architecture in the Cisco Catalyst 9300 Series Switches has been designed to provide 480G of stack bandwidth. The software architecture uses the credit-based token algorithm. To optimally forward the traffic within the stack ring, the packet-stripping function is performed on the destination switch instead of on the source or ingress switch. This mechanism is known as the spatial-reuse forwarding mechanism.

It allows multiple flows to coexist to enable a parallel forwarding design. The spatial-reuse capability significantly boosts data-plane switching performance in the stack-ring switching architecture. The broadcast and multicast packets are still required to do source stripping, since the location of the destination device is known and there could be multiple multicast listener devices within stack ring.

Distributed forwarding architecture

The forwarding architecture is designed to provide distributed switching across all member switches in the stack, as implemented in distributed, modular Cisco platforms. To optimize data-plane performance by using hardware resources from each Cisco Catalyst 9300 Series stack member switch, network services such as QoS, security ACLs, and others are fully distributed and programmed to locally enforce on network ports. This distributed hardware resource utilization process delivers wire-speed switching performance that increases overall system resource capacity, prevents centralized overload processing on the ACTIVE switch, and optimizes stack-ring bandwidth capacity.

Since Cisco StackWise-480 technology is designed to offer modular-class system redundancy in stack design, It requires centralized control and a management plane with a distributed forwarding architecture. To logically appear as a single virtual switch, the IOS daemon (IOSd) process on the ACTIVE switch centrally manages all management-plane and network-control-plane operations with Layer 2 and Layer 3 protocols, including Spanning Tree Protocol (STP), IP routing, Cisco Express Forwarding, Policy-Based Routing (PBR), and others.

Depending on the implemented network protocols, the ACTIVE switch communicates with the rest of the multilayer or routed access infrastructure to dynamically develop the forwarding tables. The ACTIVE switch also updates all member switches for forwarding information. The distributed forwarding capability provides local switching lookup for the switching decision process. All ingress and egress wired data-plane traffic is fully distributed in a StackWise-480-based system design.

Independent of the IOSd operational state, the hardware Forwarding Information Base (FIB) is actively programmed in ASICs across all stack-member switches in a stack ring. Figure 7 shows the Cisco Catalyst 9300 Series system architecture with centralized processing for control and management functions and distributed forwarding.

Figure 7. Cisco Catalyst 9300 Series and centralized processing

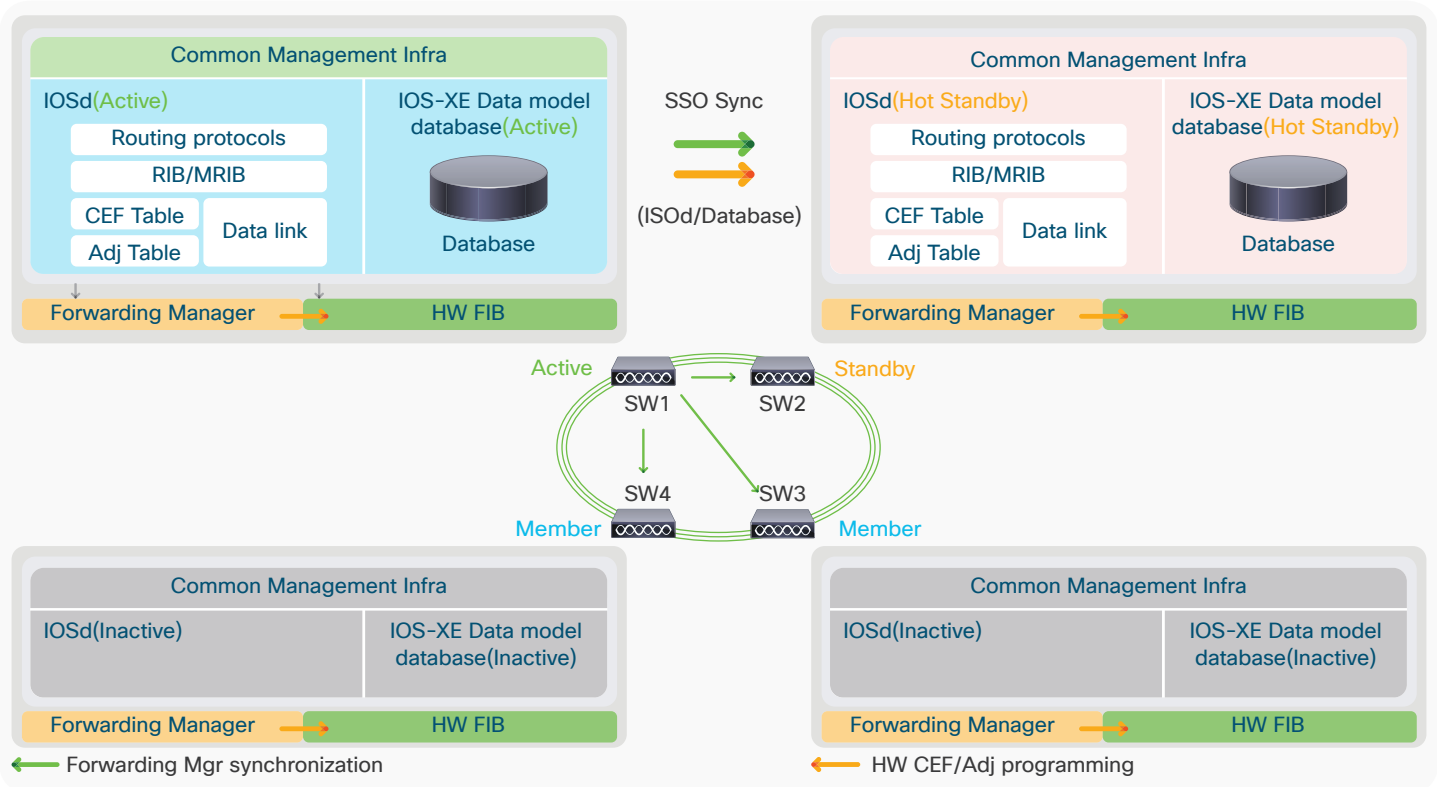

SSO/NSF architecture

The highly resilient Nonstop Forwarding and Stateful Switchover (NSF/SSO) technology is a widely deployed solution in mission-critical campus and branch network designs. The key advantage of NSF/SSO is that it constantly delivers network availability without compromising performance and scalability during planned or unplanned network outages. The StackWise-480 architecture takes advantage of the same technology to maintain state machines and gracefully recover during an ACTIVE switch failure.

StackWise-480 SSO technology expands Route Processor Redundancy (RPR) capabilities to provide transparent failover of several high-availability-aware Layer 2 and 3 protocols and Cisco IOS Software applications when the ACTIVE switchover occurs.

The state machines of non-high-availability-aware protocols and applications are not synchronized from ACTIVE to STANDBY, something the Cisco Catalyst 9300 Series Switch requires to rebuild adjacencies and forwarding entries during an ACTIVE switch failure.

NSF is a high-availability feature that can ensure continuous Layer 2 and 3 packet forwarding, which continues when an ACTIVE route processor switches over to a STANDBY switch. It effectively increases network availability by eliminating network downtime in the event of scheduled maintenance or an unexpected failure of the switch. NSF is used in conjunction with SSO. NSF enhances the Cisco Express Forwarding logic to allow Cisco Catalyst 9300 Series Switches in StackWise-480 to continue using their last known forwarding information base data when a newly elected ACTIVE switch is learning routes.

Figure 8 shows the NSF/SSO architecture in Cisco Catalyst 9300 Series StackWise-480 mode.

Figure 8. Cisco Catalyst 9300 Series StackWise-480 NSF/SSO architecture

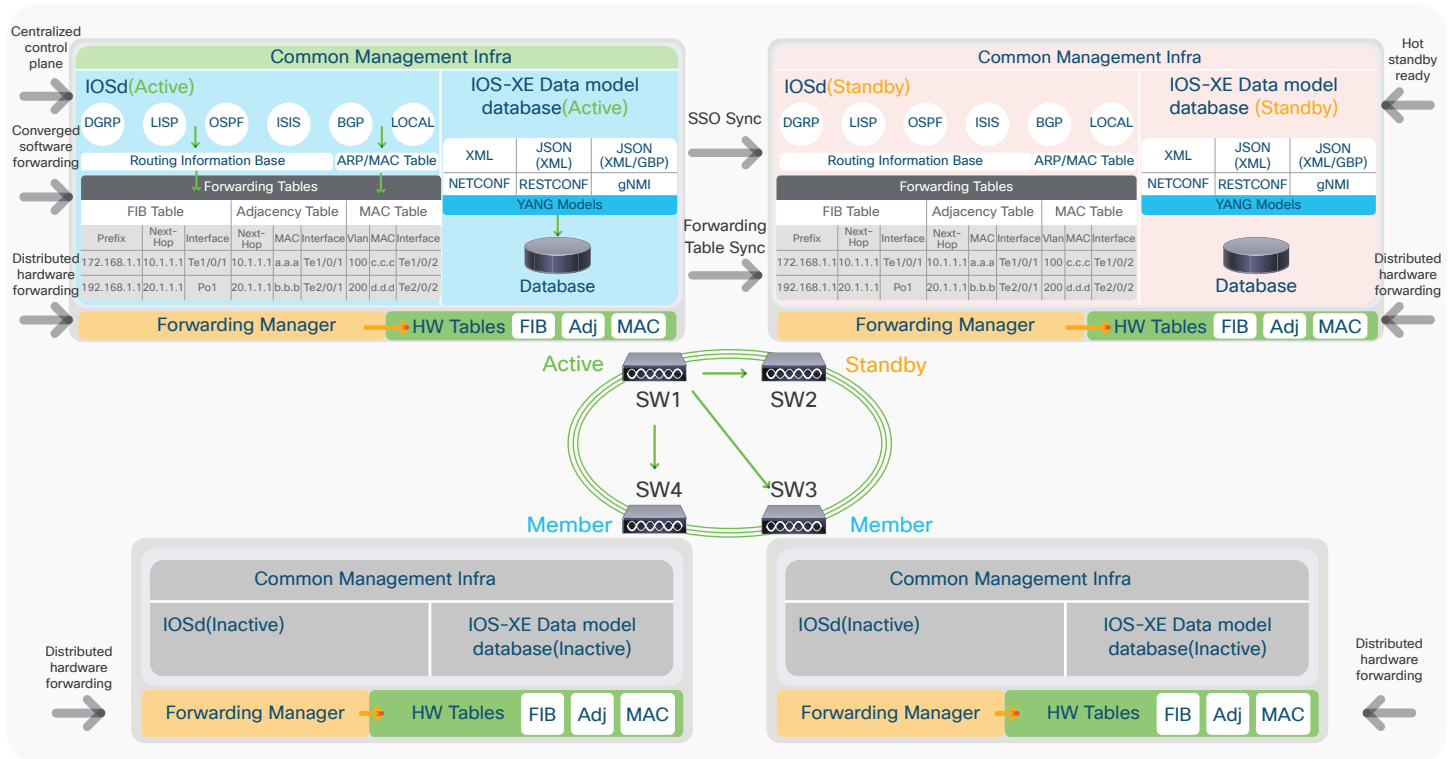

Implementing StackWise-480 NSF/SSO

To increase availability, the SSO capability is enabled by default when Cisco Catalyst 9300 Series Switches are deployed in StackWise-480 mode. No additional user intervention is required to enable the SSO capability on a Cisco Catalyst 9300 Series system. The user can verify that SSO is configured and that the operational state is using a consistent CLI as a modular Cisco Catalyst system. The following example shows the sample output of SSO redundancy in the StackWise-480-based network design.

```
9300-STACK#sh redundancy states
```

```
my state = 13 -ACTIVE
peer state = 8 -STANDBY HOT
Mode = Duplex
Unit = Primary
Unit ID = 1
```

```
Redundancy Mode (Operational) = sso
```

```
Redundancy Mode (Configured) = sso
```

```
Redundancy State = sso
```

```
Maintenance Mode = Disabled
```

```
Manual Swact = enabled
```

```
Communications = Up
```

```
client count = 109
```

```
client_notification_TMR = 30000 milliseconds
```

```
RF debug mask = 0x0
```

The NSF capability on Cisco Catalyst 9300 Series Switches can perform as an NSF helper system. However, with SSO protocol synchronization, the Cisco Catalyst 9300 Series system becomes an NSF-capable system as a modular Cisco Catalyst system. To enable the graceful restart capability for supported protocols, the network administrator must manually enable the graceful restart capability under a routing instance; otherwise the system may not gracefully recover protocol state machines and may cause a high recovery time during an ACTIVE switch failure event. The following code shows an example of how to enable NSF for the Enhanced Interior Gateway Routing Protocol (EIGRP).

```
9300-STACK(config)#router eigrp 100
9300-STACK(config-router)#nsf

9300-STACK#sh ip protocols
*** IP Routing is NSF aware ***

Routing Protocol is "eigrp 100"
<SNIP>

NSF-aware route hold timer is 240
EIGRP NSF enabled
NSF signal timer is 20s
NSF converge timer is 120s
Router-ID: 172.168.2.2
```

Stack operations

Switch addition

When adding a new switch to the stack, stack cables have to be connected appropriately prior to powering on the switch. The stack will operate at half bandwidth until the newly added switch has been powered on and has been discovered as a member. Once the switch had been discovered and is part of the stack, the stack ring transitions to the "Full" state.

The following output shows that the stack is in "Half" ring state until the newly added switch is discovered.

```
9300-STACK#show switch stack-ring speed
Stack Ring Speed           : 240G
Stack Ring Configuration   : Half
Stack Ring Protocol        : StackWise
```

Figure 9 shows the stack cabling when three switches are operating in StackWise-480.

Figure 9. Stack with three switches

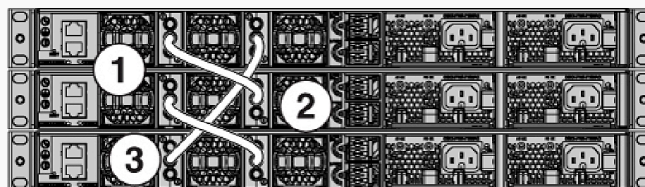
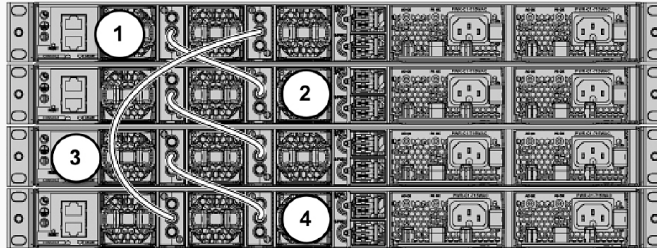

Figure 10 shows the stacking cable structure when a fourth switch has been added to the above stack.

Figure 10. StackWise-480 with four switches



The following logs describe the addition of a new switch to the stack.

Newly added member switch logs

```
Initializing Hardware...
<SNIP>
Current ROMMON image: Primary
Last reset cause : PowerOn
C9300-24UX platform with 8388608 Kbytes of main memory
boot: attempting to boot from [flash:packages.conf]
boot: reading file packages.conf
< SNIP >
Waiting for 120 seconds for other switches to boot
The switch number is 4
All switches in the stack have been discovered. Accelerating discovery
```

The stack discovers this new switch and assigns a switch number of 4, as seen below:

```
9300-STACK#
*Aug 20 18:44:51.427: %STACKMGR-6-SWITCH_ADDED: Switch 2 R0/0: stack_mgr: Switch 4 has
been added to the stack.
*Aug 20 18:44:51.428: %STACKMGR-6-SWITCH_ADDED: Switch 1 R0/0: stack_mgr: Switch 4 has
been added to the stack.
*Aug 20 18:44:51.430: %STACKMGR-6-SWITCH_ADDED: Switch 3 R0/0: stack_mgr: Switch 4 has
been added to the stack.
<SNIP>
*Aug 20 18:44:57.034: %STACKMGR-6-SWITCH_ADDED: Switch 4 R0/0: stack_mgr: Switch 4 has
been added to the stack.
*Aug 20 18:44:57.034: %STACKMGR-6-SWITCH_ADDED: Switch 4 R0/0: stack_mgr: Switch 4 has
been added to the stack.
*Aug 20 18:44:57.249: %HMANRP-6-HMAN_IOS_CHANNEL_INFO: HMAN-IOS channel event for
switch 4: EMP_RELAY: Channel UP!
```

It is recommended to have the stack cables connected to the newly added switch prior to powering it on. If the stack cables are connected after the switch has been powered on, it will result in reload of the newly added switch. A similar message will be seen during this process on the new switch, resulting in a reload:

“Chassis 1 reloading, reason - stack merge”

Switch deletion

To remove a switch from the stack, the respective switch has to be powered down and the stack cables have to be disconnected from the switch. The stack will operate at half bandwidth during this state until the stack cables are reconnected to form a full ring.

Figures 11 and 12 show stack cable connections before and after the removal of SW-4 from the stack.

Figure 11. Stack cable connections with four switches in the stack

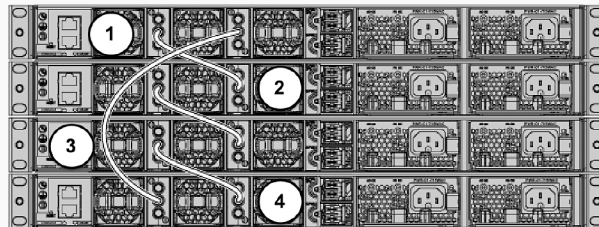

SW-4 has been removed and the stack cable connections have been moved to bring the ring to the “Full” state.

Figure 12. Stack cable connections after switch 4 has been removed from the stack

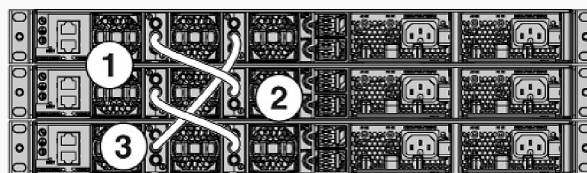

Stack split

Figure 13 shows a common stack split scenario.

Figure 13. Stack split scenario

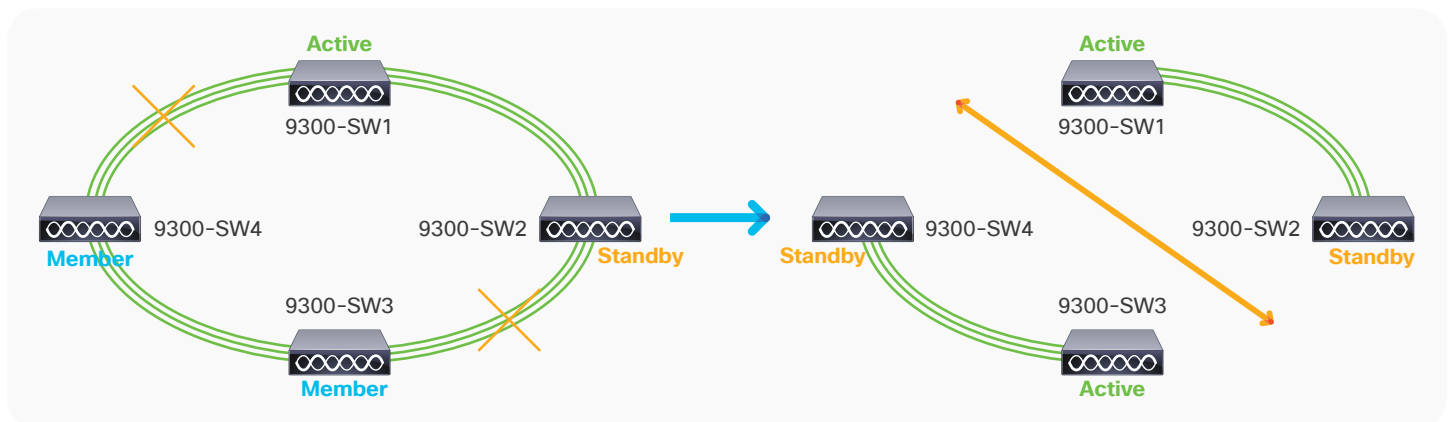

When a stack split happens for unforeseen reasons, the member switches reload as they lose connectivity to both the ACTIVE and STANDBY switches, as shown in Figure 13.

Chassis 3 reloading, reason - lost both active and standby
Chassis 4 reloading, reason - lost both active and standby

SW-3 and SW-4 discover each other during the reload process and the ACTIVE switch is elected. The ACTIVE switch elects the STANDBY switch. In this scenario, the stack ring will continue to operate at half bandwidth until the link has been restored.

Figure 14 illustrates another stack-split scenario.

Figure 14. Another stack split scenario

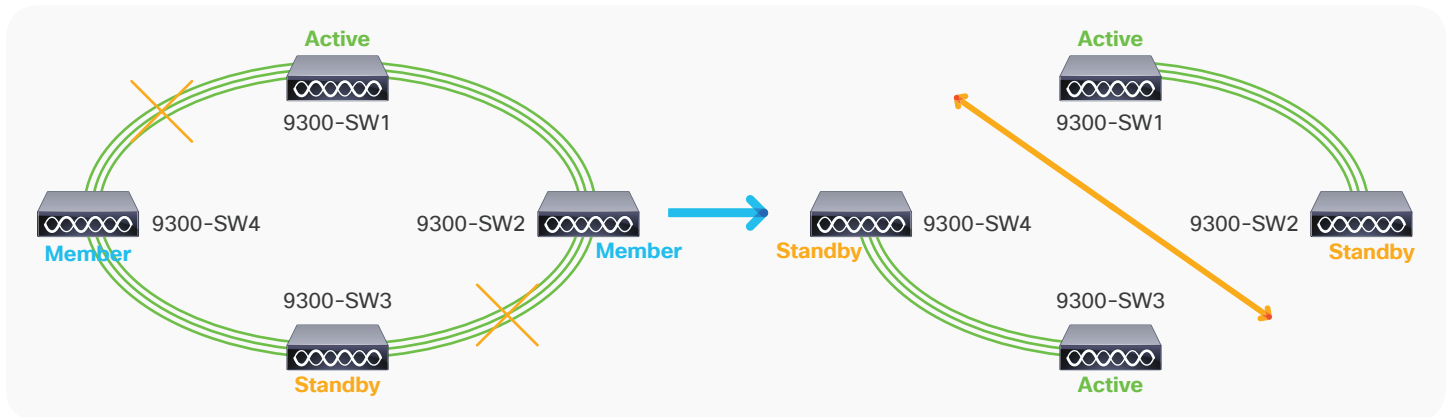

The scenario in Figure 14 shows a stack split with the ACTIVE and STANDBY switches being split. In this scenario, none of the switches reload, as both the right half and left half have either an ACTIVE or STANDBY switch. In the right half topology, a new standby switch is elected. In the left half topology, the STANDBY switch takes over the ACTIVE role and a new STANDBY switch is elected. Both topologies operate at half bandwidth until the stack link restores.

Stack merge

When a stack merge occurs, as shown in Figure 15, the stack pair that has the lowest priority on the ACTIVE switch will reload and join the stack pair that has the highest priority. If the priority is the same, the ACTIVE switch in the stack pair with the highest MAC address reloads.

Figure 15. Stack merge scenario

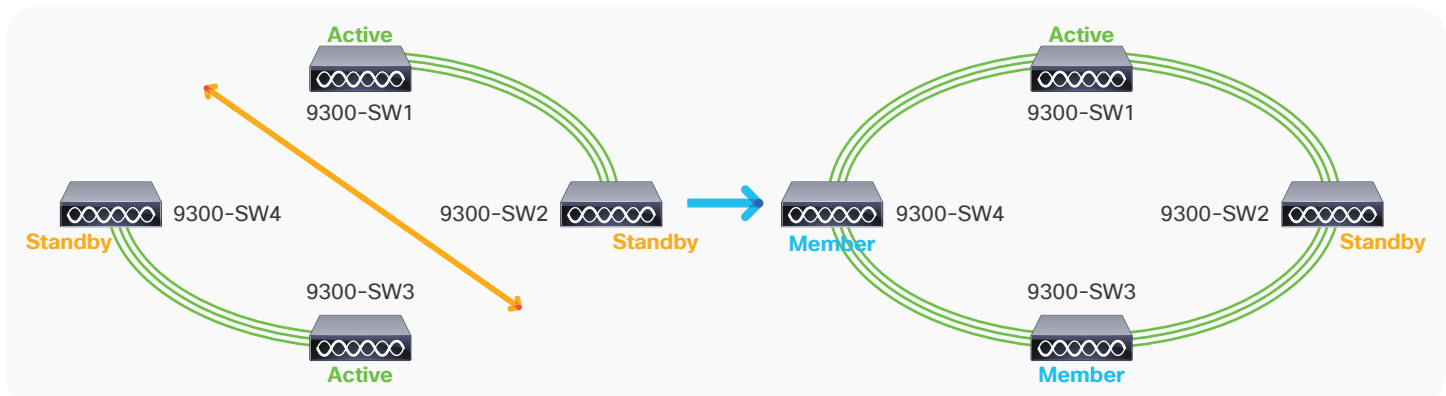

In Figure 15, considering that SW-1 has a priority of 15, SW-2 has a priority of 14, SW-3 has a priority of 13, and SW-4 has a priority of 12, the stack merge will result in a reload of all switches only in the left half of the stack (SW3 and SW4), as they have a lower priority. The stack operates at “Half” ring until the switches in the left half have been discovered as members. If the priority is the same for all switches, the stack with the highest MAC address will reload.

Auto-upgrade

One of the options that gives the StackWise-480 architecture greater flexibility is the ability to increase the number of ports in the wiring closet without needing to configure the management plane or upgrade the newly installed switch manually. The newly added switch automatically upgrades to the software that the stack is currently running, without any manual intervention. The hardware and software architecture of the Cisco Catalyst 9300 Series continues to provide backward compatibility to dynamically insert a new 9300 Series switch into the stack ring without a major network disruption. The system and management operation, network configuration, and topologies remain transparent for network upgrades and nonstop business communication.

As a best practice, the newly joined switch can automatically receive consistent software versions from an ACTIVE switch and bring the system online without any user intervention. To automatically download consistent software versions to newly joined switches, you can use the following command from the global configuration mode. The auto-upgrade feature is not supported in bundled mode.

```
9300-STACK#conf t
```

Enter configuration commands, one per line. End with CNTL/Z.

9300-STACK(config)#software auto-upgrade enable

With the aforementioned command enabled, any member switch that is added to the stack will automatically upgrade to the current stack software.

Stack logs

```
9300-STACK#
```

```
*Aug 20 22:56:20.696: %STACKMGR-6-SWITCH_ADDED: Switch 2 R0/0: stack_mgr: Switch 4 has been added to the stack.
```

```
*Aug 20 22:56:20.697: %STACKMGR-6-SWITCH_ADDED: Switch 1 R0/0: stack_mgr: Switch 4 has been added to the stack.
```

```
*Aug 20 22:56:20.740: %STACKMGR-6-SWITCH_ADDED: Switch 3 R0/0: stack_mgr: Switch 4 has been added to the stack.
```

```
*Aug 20 22:56:21.172: %BOOT-3-BOOTTIME_INCOMPATIBLE_SW_DETECTED: Switch 1 R0/0: issu_stack: Incompatible software detected. Details: Chassis 4 is detected INCOMPATIBLE with software version of Active: FAILED: Version '16.06.03' mismatch with Active's running version '16.09.01' for package: 'guestshell'
```

```
*Aug 20 22:56:21.298: %AUTO_UPGRADE-5-AUTO_UPGRADE_START_CHECK: Switch 1 R0/0: auto_upgrade_client: Auto upgrade start checking for incompatible switches.
```

```
*Aug 20 22:56:24.452: %IOSXE_INFRA-6-PROCPATH_CLIENT_HOG: IOS shim client 'chasfs' has taken 3168 msec (runtime: 0 msec) to process a 'stack chasfs fd' message
```

```
*Aug 20 22:56:25.476: %AUTO_UPGRADE-5-AUTO_UPGRADE_INITIATED: Switch 1 R0/0: auto_upgrade_client: Auto upgrade initiated for switch 4.
```

```
*Aug 20 22:56:25.502: %AUTO_UPGRADE-5-AUTO_UPGRADE_SEARCH: Switch 1 R0/0: auto_upgrade_client: Searching stack for software to upgrade switch 4.
```

Stack logs

```
*Aug 20 22:56:25.518: %AUTO_UPGRADE-5-AUTO_UPGRADE_FOUND: Switch 1 R0/0: auto_upgrade_client:
Found donor switch 1 to auto upgrade switch 4.
*Aug 20 22:56:25.534: %AUTO_UPGRADE-5-AUTO_UPGRADE_START: Switch 1 R0/0: auto_upgrade_client:
Upgrading switch 4 with software from switch 1.
*Aug 20 22:57:05.536: %AUTO_UPGRADE_MODULAR-5-SMU_AUTO_UPGRADE_INITIATING: Switch 1 R0/0:
auto_upgrade_client: Initiating SMU autoupgrade for switch 4
*Aug 20 22:57:05.904: %AUTO_UPGRADE-5-AUTO_UPGRADE_FINISH: Switch 1 R0/0: auto_upgrade_client:
Finished installing software on switch 4. → upgrade complete
*Aug 20 22:57:09.625: %AUTO_UPGRADE-5-AUTO_UPGRADE_RELOAD: Switch 1 R0/0: auto_upgrade_client:
Reloading switch 4 to complete the auto upgrade. → reload after upgrade

<SNIP >

*Aug 20 23:00:07.066: %STACKMGR-6-SWITCH_ADDED: Switch 4 R0/0: stack_mgr: Switch 4 has been added
to the stack.
```

Licensing

Licensing with Release 16.9 (Smart Licensing)

With Release 16.9.1, for which a Smart License is mandatory, the stack automatically enables the EVAL license on a new switch should a license mismatch be present on the newly added switch. Data programming will be done once the switch joins the stack.

This can be verified using the following command.

```
9300-STACK#sh license usage
License Authorization:
  Status: AUTHORIZED on Sep 25 22:53:33 2018 UTC

C9300 Network Advantage (C9300-24 Network Advantage):
  Description: C9300-24P Network Advantage
  Count: 4 → Number of switches in stack
  Version: 1.0
  Status: AUTHORIZED

C9300 Cisco DNA Advantage (C9300-24 Cisco DNA Advantage):
  Description: C9300-24P Cisco DNA Advantage
  Count: 4
  Version: 1.0
  Status: AUTHORIZED
```

Licensing prior to Release 16.9

Prior to Release 16.9.1, any newly added switch must have the same license as the stack to join the stack. If the newly installed switch does not have same license as the stack, the switch will be discovered but will not join the stack and will be reported as a license mismatch. No data programming will be done for this switch until the compatibility check is passed.

The following message will appear when a switch experiences a license mismatch:

Logs on the newly added switch with license mismatch

```
"Switch 4 has a license mismatch with the stack. Only on activating a compatible license will the switch join."
```

Stack reports the license mismatch

```
c9300-STACK#sh switch
Switch/Stack Mac Address : 046c.9d1f.3b80 - Local Mac Address
Mac persistency wait time: Indefinite
```

Switch#	Role	Mac Address	Priority	H/W Version	Current State
*1	Active	046c.9d1f.3b80	15	V01	Ready
2	Standby	046c.9d1f.3400	14	V01	Ready
3	Member	046c.9d1f.6c00	13	V01	Ready
4	Member	7001.b544.5700	12	V01	Lic-Mismatch

Manual intervention is needed to resolve this issue. This can be corrected by activating a Right-To-Use (RTU) license, followed by reloading the switch.

```
c9300-1#license right-to-use activate network-advantage slot 4 acceptEULA
c9300-1#license right-to-use activate addon Cisco DNA-advantage evaluation slot 4 acceptEULA
c9300-1#reload slot 4
```

Stack design

Simplified multilayer network design

The enterprise customer relies on real-time business applications such as voice, video, and others. The system reliability and network availability become a core, integrated service requirement to deliver nonstop communication in the network.

When the access layer environment becomes highly dense, the StackWise-480 pools up to eight physical chassis into a single logical system from a network design perspective. As the access layer network infrastructure expands, the device-pooling capability of the Cisco StackWise-480 technology significantly simplifies operations and the network architecture itself.

Cisco recommends designing and deploying the multilayer distribution block with four major elements in the overall architecture: reduced fault domain, increased network security, deterministic forwarding paths, and optimal resiliency.

Designing and developing a wiring closet with this architecture requires isolated broadcast domains or VLANs for each workgroup category, device, and application type. This network design needs to apply consistently throughout the wiring closet network. It provides solid network security, stability, and reliability, and depending on the access layer network size, it may increase operational and troubleshooting complexity due to the increased number of VLANs, subnets, neighbor counts, and more.

The Cisco Catalyst 9300 Series StackWise-480 device-pooling design retains Cisco’s multilayer design principles. It also simplifies operational challenges with a reduced number of VLANs, STP instances, subnets, neighbor counts, etc. at the access and distribution layers. Figure 16 shows the simplified network design and operational data points between 9300 Series switches deployed in standalone mode in comparison to StackWise-480 mode.

Figure 16. Comparison of Cisco Catalyst 9300 Series Switches in standalone mode to a StackWise-480 multilayer network design

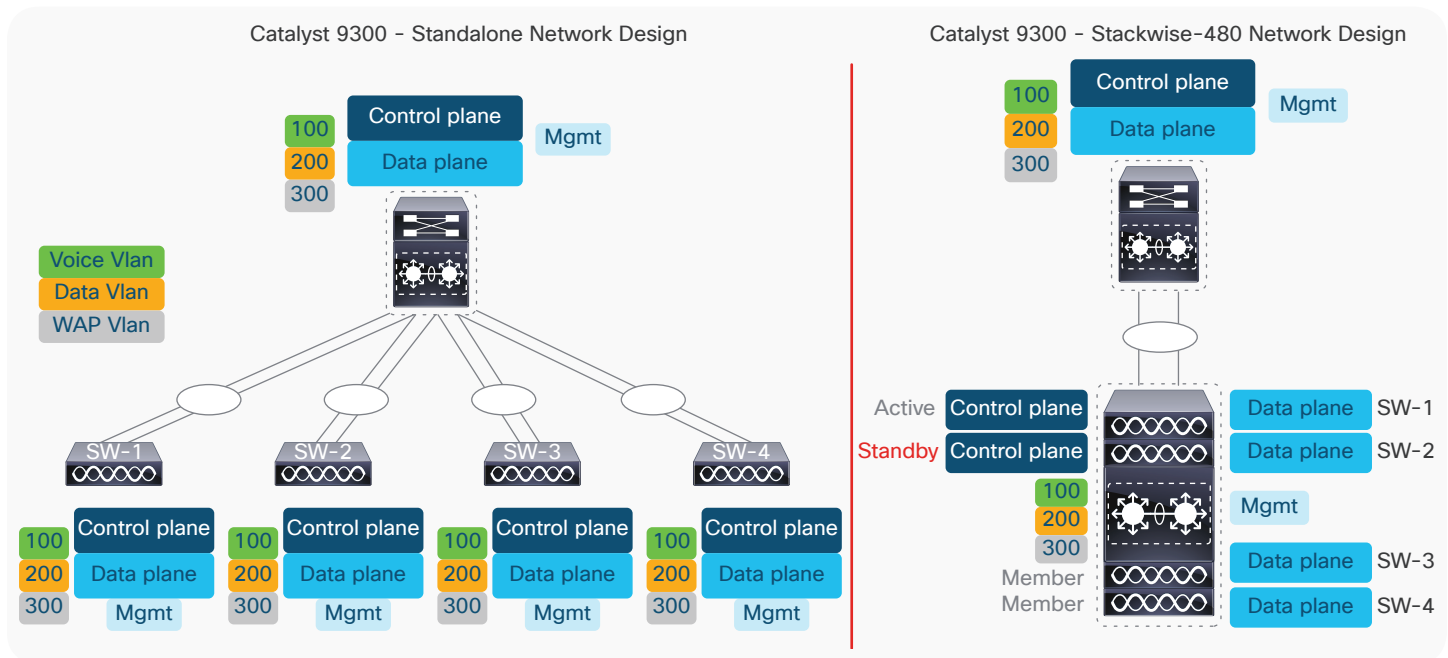

Scalable StackWise-480 cross-stack EtherChannel design

StackWise-480 can enable the ability to build a single-uplink EtherChannel interface by bundling up to eight parallel physical links, which could then be distributed evenly across all stack switches. Multiple uplinks from a mission-critical access layer switch are a base requirement for reliable networks to provide high-speed data load sharing and to deliver 1+1 path redundancy upon failure.

However, from a forwarding perspective the Layer 2 network becomes suboptimal when multiple parallel interfaces are deployed between two Layer 2 Ethernet switches.

The cross-stack EtherChannel interface simplifies STP topology over the logical interface and builds loop-free forwarding paths across all bundled uplink ports. If the Cisco Catalyst 9300 Series Switch is deployed in routed access mode, the cross-stack EtherChannel can also be deployed as a Layer 3 uplink interface to simplify unicast or multicast neighbor adjacencies and simplified network topology with one forwarding table. Independent of the 9300 Series switch’s deployed mode (multilayer or routed access), during the member switch or member link failure the EtherChannel does not disrupt network topology tables and delivers deterministic, hardware-driven, subsecond network recovery processes.

Cisco Catalyst 9300 Series Switches support multiple physical uplink ports to connect distribution-layer switches. Typically, up to two physical uplink interfaces are deployed from access layer switches for optimal load balancing and redundancy in the wiring closet.

When these switches are deployed in stack configuration mode, we recommend maintaining the same uplink connection design principle as a dual stack-member system. The recommendation is to use uplinks on the member switches with Multichassis EtherChannel (MEC), which helps with spanning multiple uplinks over the member switches. For example, eight Cisco Catalyst 9300 Series Switches deployed in a stack ring would have multiple diversified uplink ports from member switches. The remaining switches, where uplinks are not connected, would forward the data toward the core using a high-speed stack backplane.

This recommended uplink port design offers various benefits, from application performance to optimal user experience. Some key benefits include:

- Improved application performance by increasing aggregated stack switching capacity with multiple, distributed, high-speed 10-Gbps/40-Gbps uplinks between stack member Cisco Catalyst switches
- Enhanced bidirectional traffic engineering with intelligent network data load sharing within the stack ring and across all distributed uplink physical ports
- Improved system and application performance by using the distributed forwarding architecture advantage of hardware resources: buffers, queues, Ternary Content-Addressable Memory (TCAM), and others
- Protection of the stack and network-level redundancy and reduction in congestion between distributed aggregation systems caused during a major outage at the access or distribution layer

Figure 17 illustrates a sample Cisco Catalyst 9300 Series StackWise-480 uplink network design of the distribution layer system.

Figure 17. Cisco Catalyst 9300 Series StackWise-480 uplink design best practices

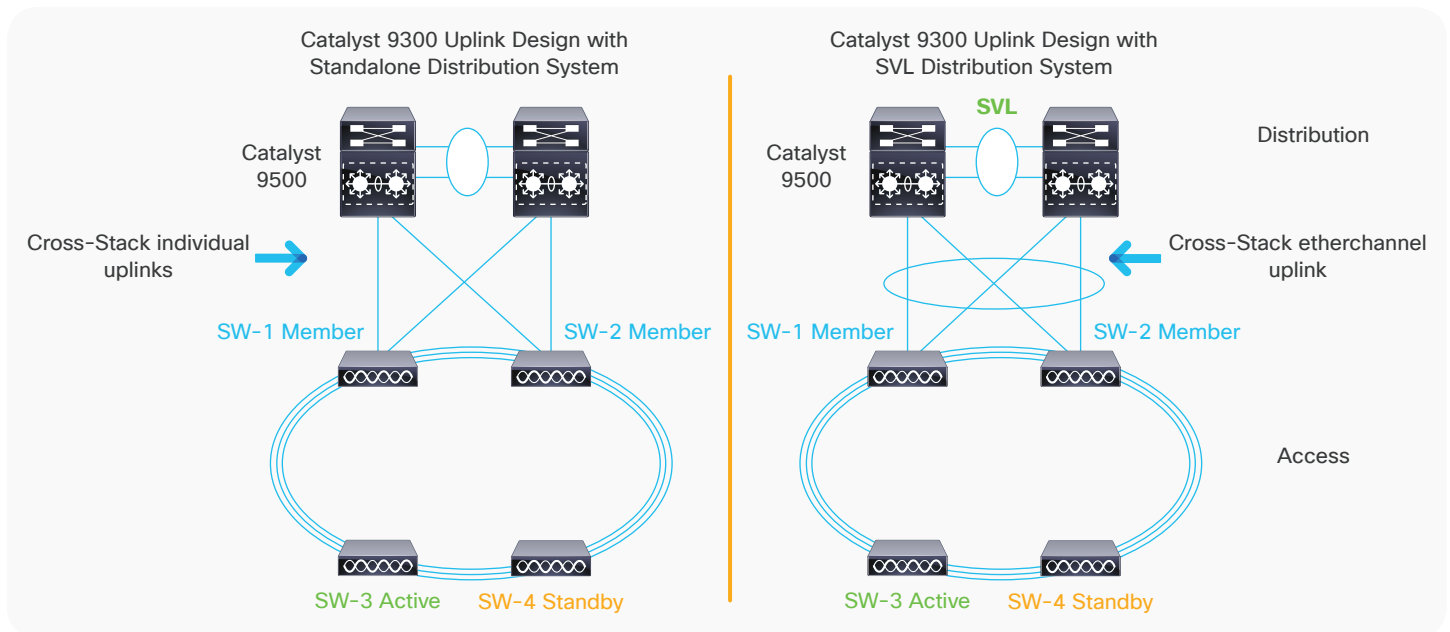

Optimal StackWise-480 cross-stack forwarding EtherChannel design

The egress data load forwarding from StackWise-480 is determined based on how the upstream network is designed. The loop-free forwarding topology uses all available paths to switch data traffic based on precomputed Cisco Express Forwarding or EtherChannel hash results. In a distributed forwarding architecture the Cisco Catalyst 9300 Series stack switches verify the Layer 2 to Layer 3 data variables from incoming traffic to determine the best physical uplink ports before forwarding traffic to the upstream system.

The Cisco Catalyst 9300 Series Switch requires more variables in packet tuples to perform granular switching decisions. In a large-scale design, the source MAC address-based EtherChannel load-sharing mode may deliver adequate results to use all upstream member links. However, in mid- to low-scale networks, the Cisco Catalyst 9300 Series may not have enough variable points to compute the best egress uplink path. In this case, in order to optimize the switching performance with granular packet forwarding decisions across all available cross-stack uplink paths, the default EtherChannel hash computation can be tuned to include Layer 2 to Layer 3 address variables.

The next-generation Cisco Catalyst 9300 Series is designed to support a large number of EtherChannel hash variables to deliver optimal upstream egress forwarding decisions. Table 3 outlines the supported Layer 2 to Layer 4 EtherChannel hash algorithm.

Table 3. Cisco Catalyst 9300 Series EtherChannel hash algorithm

Layer	EtherChannel hash
Non-IP	src-mac (default)
Layer 2	src-mac (default) dst-mac src-dst-mac
Layer 3	src-ip dst-ip src-dst-ip
Layer 4	src-port dst-port src-dst-port
Layer 3 plus layer 4	src-mixed-ip-port dst-mixed-ip-port src-dst-mixed-ip-port (Recommended)

The network administrator can adjust the default EtherChannel hash algorithm from a global configuration mode, as demonstrated in the sample code that follows.

Verification:

```
9300-STACK#show etherchannel load-balance
EtherChannel Load-Balancing Configuration:
    src-mac

EtherChannel Load-Balancing Addresses Used Per-Protocol:
Non-IP: Source MAC address
IPv4: Source MAC address
IPv6: Source MAC address
```

Command to change the default load-balance method:

```
9300-STACK#conf t
9300-STACK(config)#port-channel load-balance src-dst-mixed-ip-port
```

Verification:

```
9300-STACK#sh etherchannel load-balance
EtherChannel Load-Balancing Configuration:
    src-dst-mixed-ip-port

EtherChannel Load-Balancing Addresses Used Per-Protocol:
Non-IP: Source XOR Destination MAC address
IPv4: Source XOR Destination IP address and TCP/UDP (layer-4) port number
IPv6: Source XOR Destination IP address and TCP/UDP (layer-4) port number
```

Reliable StackWise-480 cross-stack forwarding EtherChannel design

The link aggregation protocols build stateful, consistent, and reliable EtherChannel communication between two systems. To successfully establish a logical EtherChannel interface between two systems, the link aggregation protocol performs several link parameter checks to assure that each member link is equipped to deliver consistent switching performance and network service in the event of failure. During the EtherChannel startup process, each end of the system verifies the capabilities of each local and remote member link, including attributes such as speed, duplex, protocol dependencies, QoS capabilities, and more.

Cisco recommends bundling the cross-stack EtherChannel interface using link aggregation protocols such as Cisco Port Aggregation Protocol Plus (PAgP+) or Link Aggregation Control Protocol (LACP). The Cisco Catalyst 9300 Series Switch deployed in StackWise-480 supports both link aggregation protocols (Figure 18).

Figure 18. Cisco Catalyst 9300 Series cross-stack EtherChannel design

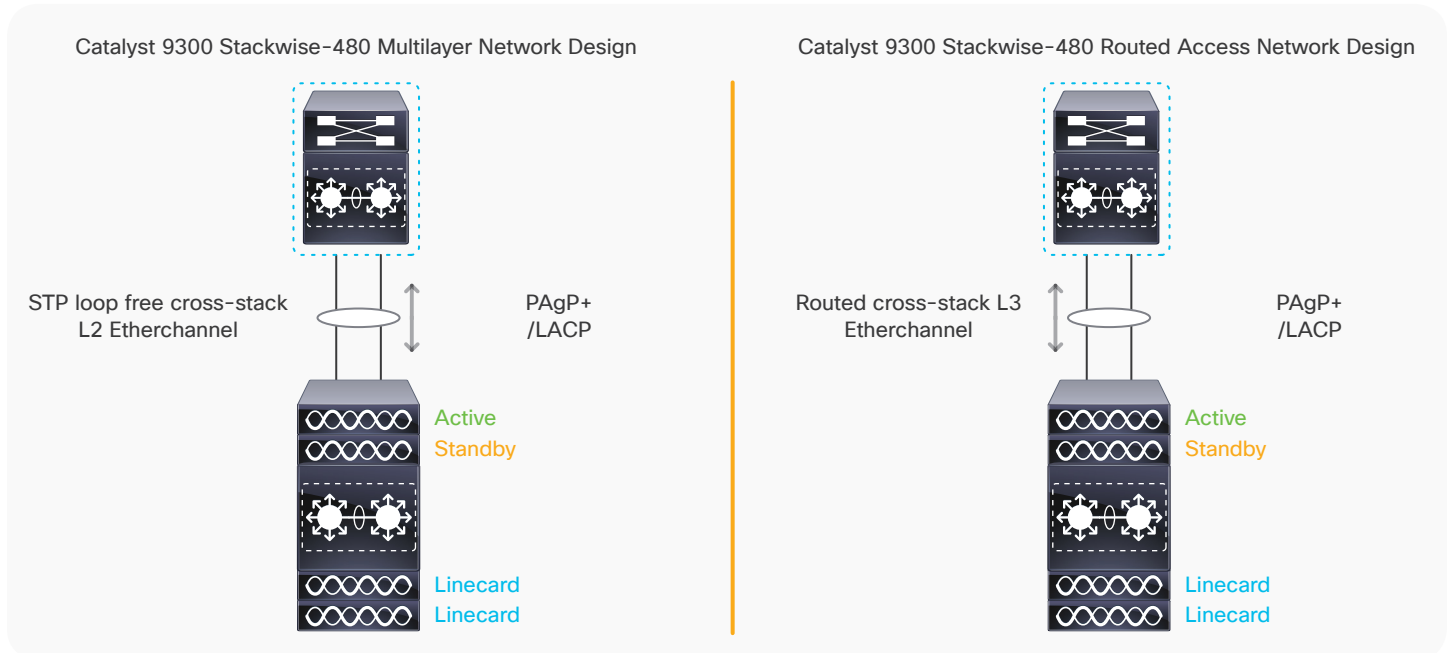

Summary

Next-generation Cisco Catalyst 9300 Series Switches have been designed to meet the future demands in wiring closet networks. Stackwise-480 provides maximum port density at the access layer, along with platform, software, and network resiliency at the access layer. As more technologies are integrated into the system, the Cisco Catalyst 9300 Series offers operational simplicity, scalability, performance, and adaptability for future protocols. The software architecture of Cisco StackWise-480 technology delivers superior performance and best-in-class resiliency along with the flexibility of a UADP ASIC. This document is primarily focused on the StackWise architecture for the Cisco Catalyst 9300 Series Switches.