

IronPort C350

These simple-to-follow steps will allow you to install, configure, and start using your IronPort Email Security appliance right away.

Before you start, be sure you have the following:

- Rack cabinet enclosure
- Dell 9G Combination Rails – Rapid/Versa Combination Rails and adaptor kits (optional)
- 10/100/Gigabit BaseT TCP/IP local area network (LAN)
- Web browser software (or SSH and terminal software)
- Network cable(s) for connecting to your network

1 UNPACK

Check to make sure the following items are present in the IronPort Email Security appliance system box:

- IronPort C350 Email Security appliance
- Dual-head power cable
- Straight power cables (2)
- Null modem serial cable
- IronPort C350 Quickstart Guide (this guide)
- IronPort AsyncOS Documentation CD
- Safety and Compliance Guide

Note:

You can download the AsyncOS Release Notes from the IronPort Customer Support Portal located at www.support.ironport.com.

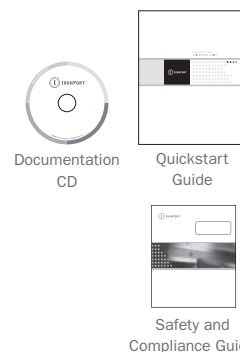
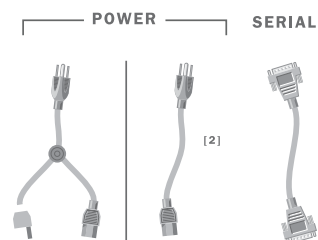
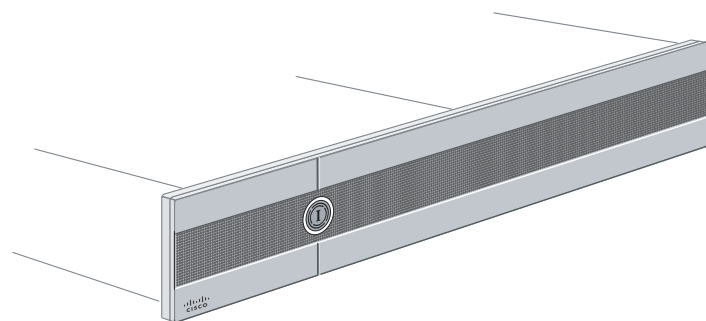

2 INSTALL

PLAN THE INSTALLATION WITHIN YOUR NETWORK

Your IronPort appliance is designed to serve as your SMTP email gateway at your network perimeter – that is, the first machine with an IP address that is directly accessible to the Internet for sending and receiving email. Many of the features (including Email Security Monitor, Reputation Filtering, Content Scanning, Spam Detection, and Virus Protection) require you to install the IronPort appliance into your existing network infrastructure in the following way.

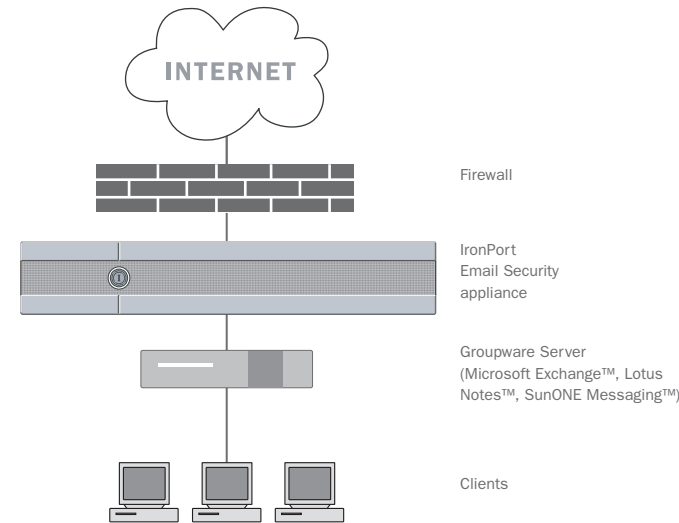

Depending on your network configuration, your firewall may need to be configured to allow access on the following ports.

SMTP and DNS services must have access to the Internet. For other system functions, the following services may be required:

- SMTP: port 25
- HTTP: port 80
- SSH: port 22
- LDAP: port 389 or 3268
- LDAP over SSL: port 636
- LDAP with SSL for Global Catalog queries: port 3269
- FTP: port 21, data port TCP 1024 and higher
- DNS: port 53
- HTTPS: port 443
- Telnet: port 23
- NTP: port 123

See the appendix, “Firewall Information” in the AsyncOS User’s Guide for more information.

INSTALL IN RACK

Install the IronPort appliance into your rack cabinet. Ensure the ambient temperature around the system is within the specified limits. Ensure there is **sufficient airflow** around the unit.

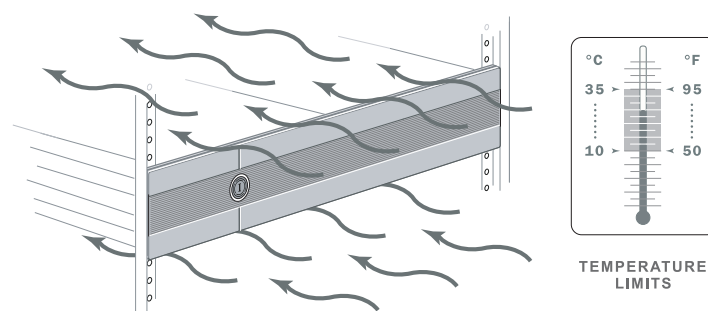

3 CONNECT

DATA

The IronPort appliance requires at least one IP address to send and receive email. Ideally, two IP addresses should be used:

- Connect the Data 1 network port to your public network
- Connect the Data 2 network port to your private network

Alternately, you can receive and deliver email from a single connection to either network port, if your network topology dictates it. Multiple IP addresses can be configured on one network interface.

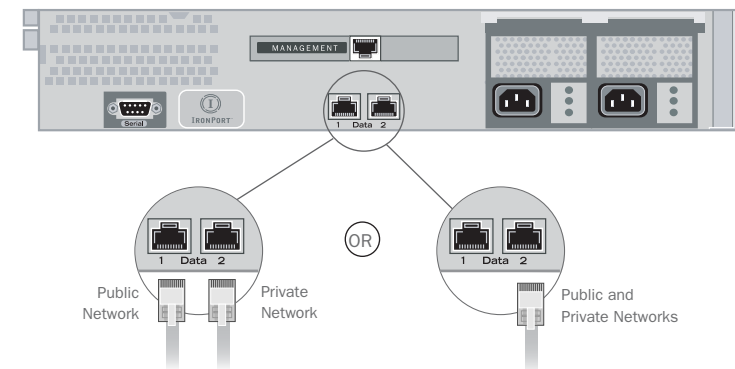

SETUP AND MANAGEMENT

- For access by Ethernet™, connect to the **Management Network Port**. Use a browser to access the web-based interface on the **default IP address 192.168.42.42**. You can also access the command line interface by **SSH** or terminal emulation software on the same IP address. (The netmask is /24.)
- Or, for Serial access, connect to the Serial Port. Access the command line interface by a terminal emulator using 9600 bits, 8 bits, no parity, 1 stop bit (**9600, 8, N, 1**), flowcontrol = Hardware.

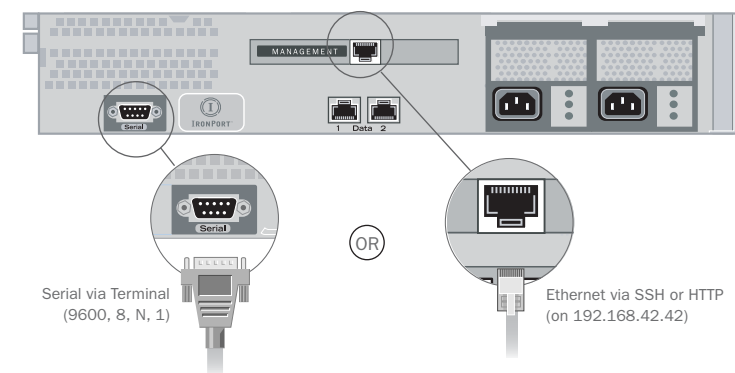

POWER

- Plug the female end of each straight power cable into the redundant power supplies on the back panel of the appliance.
- Or, plug the female ends of the dual-headed power cable into the redundant power supplies on the back panel of the appliance.

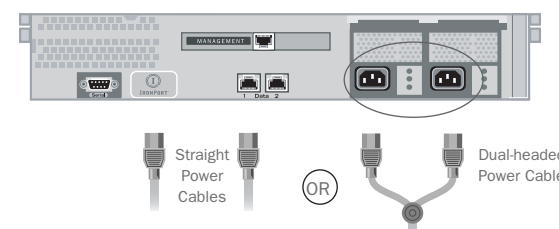

4 POWER-UP

Turn on the system power by pressing the On/Off switch on the front panel of the the appliance. You must **wait five minutes** for the system to initialize the very first time you power up before moving to Step 5.

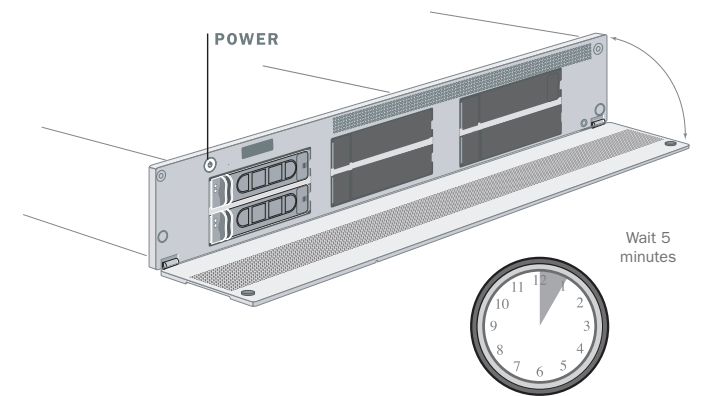

5 CONFIGURE

- Fill out the **Networking Worksheet on the back of this Quickstart Guide**. Contact your network administrator if you need assistance.
- Use a browser to **connect to the following URL:**

<http://192.168.42.42>

- Log in as: **Username: admin**
Password: ironport
- The System Setup Wizard begins and the end user license agreement is displayed. Please read and accept the license agreement to continue.
- Use the information from the Networking Worksheet to complete the System Setup Wizard.

(Or, you may connect using SSH or terminal emulation software. Initiate a session to the IP address 192.168.42.42. Log in as **admin** with the password **ironport** and, at the prompt, run the **systemsetup** command.)

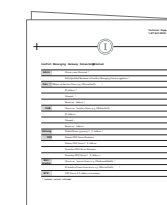

Record critical information from the Networking Worksheet to assist in completing the System Setup Wizard.