

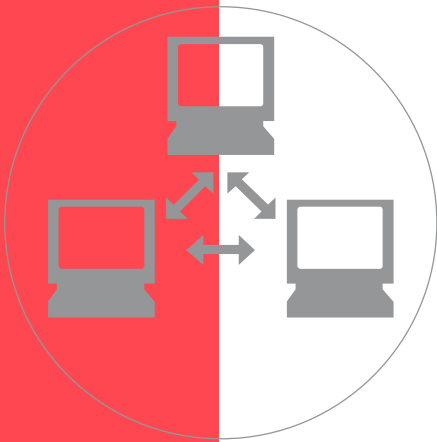

---

**The Conversion Technology Experts**

# Fiber Optics Basics



---

## Introduction

Fiber optic technology is simply the use of light to transmit data. The general use of fiber optics did not begin until the 1970s. Robert Maurer of Corning Glass Works developed a fiber with a loss of 20 dB/km, promoting the commercial use of fiber. Since that time the use of fiber optics has increased dramatically. Advances in fiber technology, lower production costs, and installation have all contributed to the wide use of fiber.

The purpose of this paper is to provide an overview of fiber, its construction, and functionality.

---

## Fiber Optics Overview

The heaviest use of fiber is in the telecommunications industry. Telephone companies initially used fiber to transport high volumes of voice traffic between central office locations. During the 1980s telephone companies began to deploy fiber throughout their networks. Fiber technology allows companies to "future proof" networks. We use the phrase "future proof" because fiber is theoretically unlimited in bandwidth. Bandwidth is a measurement of the data carrying capacity of the media (in this case, fiber). The greater the bandwidth, the more data or information that can be transmitted. Copper has a bandwidth and a distance limitation, making it less desirable.

Benefits of fiber include:

- High bandwidth for voice, video and data applications
- Optical fiber can carry thousands of times more information than copper wire. For example, a single-strand fiber strand could carry all the telephone conversations in the United States at peak hour
- Fiber is more lightweight than copper. Copper cable equals approximately 80 lbs./1000 feet while fiber weighs about 9 lbs./1000 feet
- Low loss. The higher frequency, the greater the signal loss using copper cabling. With fiber, the signal loss is the same across frequencies, except at the very highest frequencies
- Reliability - Fiber is more reliable than copper and has a longer life span
- Secure - Fiber does not emit electromagnetic interference and is difficult to tap

## Optical Fiber Construction

Optical fiber is composed of several elements. The construction of a fiber optic cable consists of a core, cladding, coating buffer, strength member and outer jacket. The optic core is the light-carrying element at the center. The core is usually made up of a combination of silica and germania. The cladding surrounding the core is made of pure silica. The cladding has a slightly lower index of refraction than the core. The lower refractive index causes the light in the core to reflect off the cladding and stay within the core.

Index of refraction is the ratio of the velocity of light in a vacuum to the velocity of light in a material. The speed of light in a vacuum is equal to 300,000,000 meters per second. The higher the index of refraction, the slower the speed of light through the material.

$$\text{Index of Refraction} = \frac{\text{Light velocity (vacuum)}}{\text{Light velocity (material)}}$$

For example:

Air = 300,000,000 meters/second

$$\text{IR} = 1$$

Glass = 200,000,000 meters/second

$$\text{IR} = 1.5$$

Fiber is either single mode or multimode. Fiber sizes are expressed by using two numbers: 8/125. The first number refers to the core size in microns. The second number refers to the core size plus the cladding size combined.

Figure 1: Fiber Construction

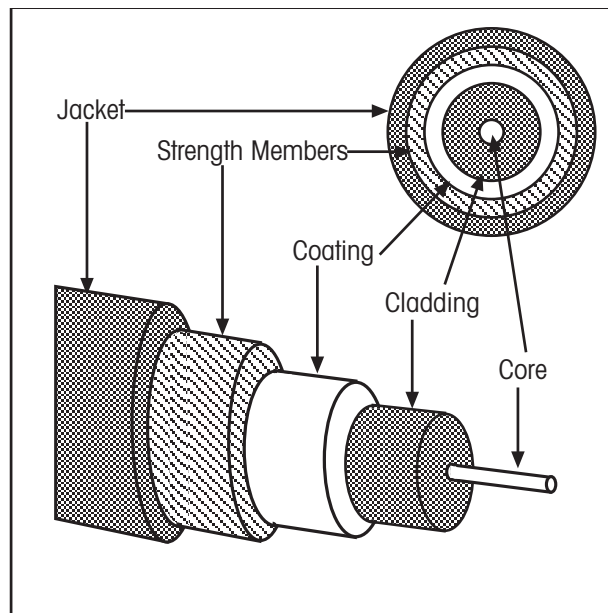

---

## Fiber Connectors

Several layers of buffer coatings protect the core and the cladding. The layers act as a shock absorber to protect the core and cladding from damage. A strength member, usually Aramid, is around the buffer layers. To prevent pulling damage during installation the strength member is added to give critical tensile (pulling) strength to the cable. The outer jacket protects against environmental factors.

The most widely used fiber connector is the SC connector. The SC connector's square cross section facilitates high packing density in connector panels. Network administrators need to take into consideration low loss, footprint size, and locking capabilities when selecting a fiber connector.

**Figure 2: Fiber Connectors**

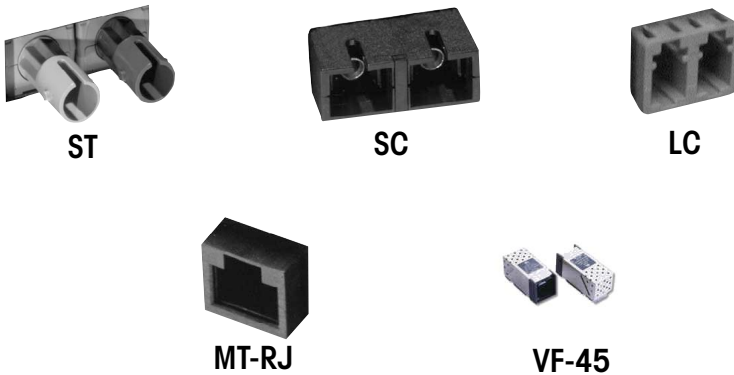

## Types of Fiber

Single mode fiber has a very small core causing light to travel in a straight line and typically has a core size of 8 or 10 microns. It has unlimited bandwidth that can go unrepeated for over 80 km, depending on the type of transmitting equipment. Single mode fiber has enormous information capacity, more than multimode fiber.

Multimode fiber supports multiple paths of light and has a much larger core and has a core size of 50 or 62.5 microns. The light travels down a much larger path in multimode fiber, allowing the light to go down several paths or modes.

Multimode fiber can be manufactured in two ways: step-index or graded index. Step-index fiber has an abrupt change or step between the index of refraction of the core and the index of refraction of the cladding. Multimode step-index fibers have lower bandwidth than other fiber designs.

Graded index fiber was designed to reduce modal dispersion inherent in step index fiber. Modal dispersion occurs as light pulses travel through the core along higher and lower order modes. Graded index fiber is made up of multiple layers with the highest index of refraction at the core. Each succeeding layer has a gradually decreasing index of refraction as the layers move away from the center. High order modes enter the outer layers of the cladding and are reflected back towards the core. Multimode graded index fibers have less attenuation (loss) of the output pulse and have higher bandwidth than multimode step-index fibers.

**Table 1:  
Single Mode and Multimode  
Characteristics**

	<b>Single Mode Fiber</b>	<b>Multimode Fiber</b>
<b>Bandwidth</b>	High	Lower
<b>Signal Quality</b>	High	Lower
<b>Main Source of Attenuation</b>	Chromatic dispersion	Modal dispersion
<b>Fiber Designs</b>	Step index, & Dispersion shifted	Step index & Graded index
<b>Application</b>	Long transmission, higher bandwidth	Short transmission, lower bandwidth

## Types of Fiber Continued...

Single mode step-index fibers are not affected by modal dispersion because light travels a single path. Single mode step-index fibers experience light pulse stretching and shrinking via chromatic dispersion. Chromatic dispersion happens when a pulse of light contains more than one wavelength. Wavelengths travel at different speeds, causing the pulse to spread. Dispersion can also occur when the optical signal gets out of the core and into the cladding, causing shrinking of the total pulse.

Single mode shifted fiber uses multiple layers of core and cladding to reduce dispersion. Dispersion shifted fibers have low attenuation (loss), longer transmission distances, and higher bandwidth.

In discussing fiber cables you will hear the terms IFC and OSP. IFC refers to an Intrafacility fiber cable. These types of cables are designed for use within a controlled environment such as a building or inside equipment. Since the cable is used within a building the cable requires less physical protection and more flexibility. Outside plant cable, or OSP, are used in hostile environments, exposed to extreme temperatures, rain, and wind. The cables are more robust and have extra layers of buffering and sheathing to protect the fiber.

Fibers are assembled into either stranded or ribbon cables. Stranded cables are individual fibers that are bundled together. Ribbon cable is constructed by grouping up to 12 fibers and coating them with plastic to form a multi fiber ribbon. Stranded and ribbon fiber bundles can be packaged together into either loose or tight buffering cable.

**Table 2: Cable Characteristics**

<b>Loose Buffered Cable</b>	<b>Tight Buffered Cable</b>
Each individual fiber bundle moves freely within the inner sheath	Fiber elements are held in place within the cable
Protects from tensile factors	Smaller in diameter with fewer fibers
Less expensive	More flexible for manipulation
More robust	More sensitive to outside forces
Higher fiber counts	Less toxic when burned
Optimized for long runs	Used in intrafacility applications
Used in OSP applications (aerial, buried, or submerged)	Cables are either distribution or breakout designs. All fiber bundles are in a single jacket or each has a separate jacket

---

## Optics

Any optical communications system consists of three components: a transmitter, a medium (fiber cable), and a receiver. The transmitter converts the electrical signal into light and sends it down the fiber. The receiver receives the optical signal and converts it back into an electrical signal. There are two types of transmitters; a laser diode or an LED (Light Emitting Diode).

**Table 3:  
Transceiver Characteristics**

<b>Optical Source Characteristics</b>	<b>Laser Diode</b>	<b>LED</b>
<b>Output Power</b>	High	Low
<b>Switching Speed</b>	Fast	Slow
<b>Output Pattern</b>	Narrow	Wide
<b>Spectral Width</b>	Narrow	Wide
<b>Operating Constraints</b>	More constraints	Fewer constraints
<b>Expense</b>	More	Less
<b>Use</b>	Single Mode	Multimode

Output power refers to the amount of power emitted at a specific drive current. The higher the output power, the longer the transmission distance. The speed at which the transmitter is able to switch on and off to meet the bandwidth requirements of the system is the switching speed. Faster switching speeds send more pulses providing greater bandwidth. The range of wavelengths emitted by the source is spectral width. A narrow spectral width means greater bandwidth.

Transceivers are evaluated on the sensitivity of the optical source to environmental condition. Laser diode requires stable voltage and temperatures. LEDs are less sensitive to environmental fluctuations. Laser diodes are more expensive to employ because of their higher performance characteristics, extra components for temperature



---

## Optics Continued...

stabilization and shorter life. LED optical sources' lower performance characteristics and longer life make them easier to install and more economical.

Transmitters are designed to emit light at one of three wavelengths: 850 nanometers, 1310 nanometers, and 1550 nanometers. These wavelengths have extremely low attenuation and therefore are a good choice for fiber optic communications. Attenuation is loss of optical power and is measured in decibels.

$$+ \text{ dB} = -10 \log_{10} \left( \frac{\text{output power}}{\text{input power}} \right)$$

Logarithmic measurement. Small changes in the decibel number represent large changes in power.

Negative sign indicates loss of signal power.

Positive sign indicates gain in power.

For example; -3dB = 50% power loss, 50% of power remains

-10dB = 90% power loss, 10% of power remains.

### Attenuation causes:

- Absorption of optical energy by tiny impurities in the fiber such as iron, copper, or cobalt
- The scattering of the light beam as it hits microscopic imperfections, called Rayleigh scattering
- Microbending, which is caused by a nick or dent in the fiber that disrupts the mode
- Macrobending occurs when the fiber is bent beyond its minimum bend radius

A receiver contains three components: a detector, amplifier, and a demodulator. The detector converts the optical signal into an electrical signal, the amplifier boosts or increases the signal strength, and demodulator extracts the original electrical signal.

When evaluating receivers you need to consider sensitivity and dynamic range. The sensitivity refers to the minimum signal strength that can be received. It is a measurement of how much light is required to accurately detect and decode the data. It is expressed in dBm and is usually a negative number. The smaller the number, the better the receiver (i.e. -30 dBm is smaller than -20dBm).

Dynamic range is the range of signal strength the receiver can accept. For example: if the receiver can accept a signal between -30dBm and -10dBm, the dynamic range is 20dB. Signals that arrive at the receiver out of the dynamic range of the receiver must be amplified or attenuated before they can be accepted.

## Optical Power Budgets

Receive sensitivity and transmitter power are used to calculate the optical power budget available for the cable. The first step in evaluating optical power budget is determining how much light is available for the electronic devices. This is accomplished by finding the minimum transmit power and the minimum receive sensitivity. These measurements are obtained from the equipment manufacturer. The minimum transmit power is the least amount of transmit power guaranteed by the device. Some vendors will publish an average transmit power. Be careful using an average because it does not guarantee the products will perform at that average level.

To calculate the available light, subtract the minimum receive sensitivity from the minimum transmit power. The minimum receive sensitivity is usually a negative number, such as -33dBm. Subtracting a negative number is the same as adding its absolute value. For example, if a device has a minimum transmit power equal to -10 dBm and a minimum receive sensitivity of -33 dBm, the available power will be 23 dBm.

$$\begin{aligned}\text{Available light} &= \text{minimum transmit power} - \text{minimum receive sensitivity} \\ &= -10 \text{ dBm} - (-33 \text{ dBm}) \\ &= 23 \text{ dBm}\end{aligned}$$

When connecting devices from different vendors or different product models, the available power calculation needs to be determined for both directions. The smaller of the two calculations should be used for the amount of available light to ensure performance.

Once the available light has been calculated, all the loss factors need to be subtracted out. Losses can stem from cable attenuation, connector loss, and cable splices. Cable attenuation is the most significant loss and is determined by using the manufacturer's worst case loss factor for the type of cable being installed. This number will range from .22 dB to .5 dB per kilometer. Multiply this number by the number of kilometers. A fiber with .4dB per kilometer of loss will lose 16 dB over a distance of 40 kilometers.

Fiber over a certain length will require splicing so you'll need to include additional loss for splicing. Fiber installers provide a worst case loss number for your calculation. Typically, each splice will introduce .1 dB of additional loss. Multiply this number times the number of splices in your fiber.

Light loss for connectors is another loss factor to consider in your calculation. The exact number of connectors for the network needs to be determined. Connector loss is provided by the connector manufacturer and the installer. Multiply the total number of connectors by the loss per connector.

## Optical Power Budgets Continued...

Each of the factors is subtracted from the original light availability. If the number is negative there is not enough power to drive the performance of the network. If the number is positive, you still need to have a buffer for anticipated repairs (additional splices in the network) and temperature extremes. This is typically done by using a safety factor in your calculation. The number differs per organization, but typically a value approximately 3 dB is used. It acts as a buffer to your power and guards against unforeseen factors affecting your optical power budget.

The table below contains some typical numbers used to approximate optical link budget. Real numbers from specific equipment manufacturers and your network should be used if at all possible.

**Table 4: Optical Link Budget Calculations**

<b>TIA Standard for connector loss</b>	.75 dB
<b>Typical cable attenuation at 1310 nm</b>	.4 dB/km
<b>Typical cable attenuation at 1550 nm</b>	.3 dB/km
<b>Typical cable attenuation at 850 nm</b>	3.75 dB/km
<b>Typical splice attenuation</b>	.1 dB/km
<b>Typical distance between splices</b>	6 km
<b>Typical safety margin</b>	3 dB

Other factors to include are the quality of the cables, connectors, and the quality of the splices. Transition Networks provides a link budget calculator on our website at [www.transition.com/learning/whitepapers/pwrbud\\_wp.htm](http://www.transition.com/learning/whitepapers/pwrbud_wp.htm)

## Conclusion

Although the widespread use of fiber began with the push from the telecommunications industry, today it is commonplace. Many enterprises take advantage of fiber to increase the capacity and functionality of their local area networks (LANs) and now metropolitan area networks (MANs).

One issue faced by some enterprises is how to connect legacy equipment and infrastructure without expensive "forklift" upgrades. By using copper to fiber media converters or multimode to single mode media converters, fiber can be connected in almost any legacy environment.

Transition Networks comprehensive line of media conversion products are designed to ease the migration to fiber, while minimizing cost and installation issues.

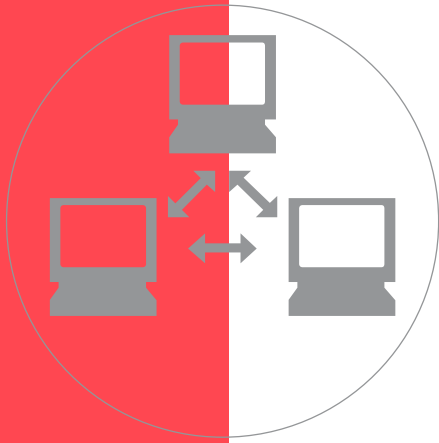

**T R A N S I T I O N**  
networks®

The Conversion Technology Experts

**USA Headquarters**

6475 City West Parkway  
Minneapolis, MN 55344 USA  
tel 952.941.7600  
toll free 800.526.9267  
fax 952.941.2322  
info@transition.com  
www.transition.com

**European Headquarters**

Puccini Centre  
Sokolska 52  
120 00 Praha 2  
Czech Republic  
tel +42 (0) 2 2426 6901  
fax +42 (0) 2 2426 6854